

# **WD Purple™ PR1000M**

Surveillance Hard Drives

**WD30PURX**

**WD20PURX**

**WD30PURZ**

**WD20PURZ**

**WD30EVRX**

**WD20EVRX**



WD CONFIDENTIAL

© 2017 Western Digital Corporation or its subsidiaries  
All Rights Reserved

Information furnished by WD is believed to be accurate and reliable. No license is granted by implication or otherwise under any patent or patent rights of WD. WD reserves the right to change specifications at any time without notice.

Western Digital, WD, and the WD logo are registered trademarks in the U.S. and other countries; and WD Purple, WD GreenPower Technology, IntelliPower, IntelliSeek, NoTouch, Data Lifeguard, CacheFlow, and FIT Lab are trademarks of Western Digital Technologies, Inc. Other marks may be mentioned herein that belong to other companies.

Western Digital  
3355 Michelson Drive, Suite 100  
Irvine, California 92612

2679-800020-A03-P3

Document Control Number Definition:

<b>2679-800xxx-</b>	<b>Axx-Px</b>	<b>NRD</b>
Doc Control No.	Doc Revision Level	Non-Released Document
	Axx = Released Version	
	Px = Review Cycle	

WD CONFIDENTIAL

# WD Purple PR1000M

## Technical Reference Manual

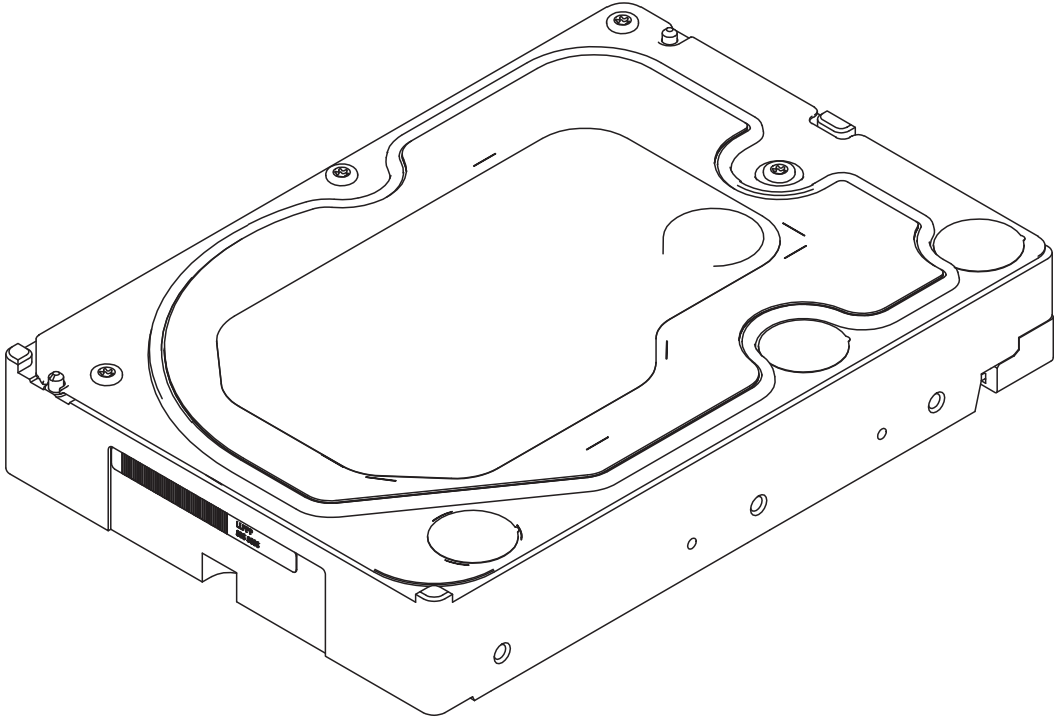



**TABLE OF CONTENTS**

**1. DESCRIPTION AND FEATURES ..... 1**

    1.1 **GENERAL DESCRIPTION..... 1**

    1.2 PRODUCT FEATURES..... 1

**2. SPECIFICATIONS ..... 4**

    2.1 Performance Specifications ..... 4

    2.2 Physical Specifications..... 4

        2.2.1 Physical Dimensions..... 5

    2.3 Mechanical Specifications..... 5

    2.4 Electrical Specifications..... 6

        2.4.1 Current Requirements and Power Dissipation..... 6

        2.4.2 Input Voltage Requirements ..... 6

        2.4.3 Ripple..... 6

        2.4.4 Power Connectors and Cables ..... 6

    2.5 Environmental Specifications..... 7

        2.5.1 Shock and Vibration ..... 7

        2.5.2 Temperature and Humidity..... 8

        2.5.3 Thermocouple Location ..... 8

        2.5.4 Cooling ..... 9

        2.5.5 Atmospheric Pressure ..... 9

        2.5.6 Acoustics ..... 9

        2.5.7 RoHS (Restriction of Hazardous Substances) ..... 9

    2.6 Reliability Specifications and Characteristics ..... 10

    2.7 Device Plug Connector Pin Definitions ..... 10

    2.8 Agency Approvals..... 12

    2.9 Full Model Number Specification..... 12

**3. PRODUCT FEATURES..... 13**

    3.1 SATA 6 Gb/s ..... 14

    3.2 AllFrame 4K..... 14

    3.3 IntelliPower ..... 14

    3.4 IntelliSeek ..... 14

    3.5 Dynamic Fly Height Control ..... 15

    3.6 Perpendicular Magnetic Recording (PMR)..... 15

    3.7 NoTouch Ramp Load Technology ..... 15

    3.8 Dual Stage Actuator Technology ..... 15

    3.9 Advanced Format (AF) ..... 15

    3.10 Native Command Queuing (NCQ) ..... 16

    3.11 Pre-emptive Wear Leveling (PWL)..... 16

    3.12 Femto Slider..... 16

    3.13 S.M.A.R.T. Command Transport (SCT)..... 16

        3.13.1 Write Same ..... 16

        3.13.2 Temperature Reporting..... 17

    3.14 World Wide Name (WWN) ..... 17

    3.15 Reliability Features Set..... 17

        3.15.1 Data Lifeguard™ ..... 17

        3.15.2 Thermal Management..... 18

        3.15.3 Internal Environmental Protection System..... 18

        3.15.4 Recoverable Errors ..... 18

        3.15.5 Unrecoverable Errors ..... 18

        3.15.6 Self Test ..... 18

        3.15.7 ATA Error Logging ..... 19

        3.15.8 Defect Management ..... 19

    3.16 Automatic Defect Retirement..... 19

        3.16.1 Error Recovery Process..... 19

    3.17 Hot Plug Support..... 20

    3.18 Active LED Status..... 20

- 3.19 Fluid Dynamic Bearings (FDB) ..... 21
- 3.20 Staggered Spinup and Activity Indication (SATA Power Pin 11) ..... 21
  - 3.20.1 Staggered Spinup..... 21
  - 3.20.2 Activity Indication ..... 21
- 3.21 CacheFlow™ ..... 21
  - 3.21.1 Write Cache..... 22
  - 3.21.2 Read Cache ..... 22
- 3.22 48-bit Logical Block Addressing (LBA) ..... 22
- 3.23 Power Management ..... 22
- 3.24 Self-Monitoring, Analysis, and Reporting Technology (S.M.A.R.T.)..... 24
- 3.25 **SECURITY MODE..... 24**
  - 3.25.1 Master and User Passwords ..... 24
  - 3.25.2 Security Levels..... 24
- 4. ATA COMMAND SET ..... 25**
  - 4.1 Host Interface Commands..... 25
    - 4.1.1 ATA-8 Commands..... 25
    - 4.1.2 SATA Commands ..... 26
    - 4.1.3 Obsolete Commands..... 26
    - 4.1.4 SCT Commands ..... 27
  - 4.2 S.M.A.R.T. (B0h)..... 27
    - 4.2.1 Read Attribute Values Sub-Command ..... 27
    - 4.2.2 Supported Attributes..... 29
    - 4.2.3 Read Log Sector..... 30
  - 4.3 Identify Device (ECh)..... 31
  - 4.4 Set Features (EFh) ..... 39
- 5. INSTALLATION AND SETUP PROCEDURES ..... 40**
  - 5.1 Unpacking..... 40
    - 5.1.1 Handling Precautions..... 40
    - 5.1.2 Inspection of Shipping Container ..... 40
    - 5.1.3 Removal From Shipping Container..... 40
    - 5.1.4 Removal From Static Shielding Bag..... 41
    - 5.1.5 Moving Precautions..... 41
  - 5.2 Mounting..... 41
    - 5.2.1 Mounting Restrictions ..... 41
    - 5.2.2 Orientation ..... 41
    - 5.2.3 Screw Size Limitations ..... 41
    - 5.2.4 Grounding..... 42
  - 5.3 Hard Drive Installation..... 42
    - 5.3.1 Jumper Settings..... 42
    - 5.3.2 **ATTACH THE POWER SUPPLY CABLE ..... 44**
    - 5.3.3 **ATTACH SATA INTERFACE CABLE ..... 44**
  - 5.4 Serial ATA Latching Connector..... 44
- 6. MAINTENANCE ..... 46**
- 7. TECHNICAL SUPPORT ..... 47**
  - 7.1 WD ONLINE SERVICES..... 47
- 8. GLOSSARY ..... 48**

**LIST OF FIGURES**

Figure 2-1 Mounting Dimensions ..... 5  
Figure 2-2 Drive Base Casting Thermocouple Location ..... 8  
Figure 2-3 Forced Airflow Direction ..... 9  
Figure 2-4 Standard Factory Connectors ..... 10  
Figure 5-1 Jumper Settings ..... 43  
Figure 5-2 Connector Locations ..... 44  
Figure 5-3 SATA Interface Cable..... 44





**LIST OF TABLES**

Table 2-1 Shock and Vibration ..... 7  
Table 2-2 Device Pin Connector Pin Definitions..... 11  
Table 2-3 Full Model Number Description ..... 12  
Table 4-1 ATA-8 Command Opcodes ..... 25  
Table 4-2 SATA Command Opcodes..... 26  
Table 4-3 Obsolete Command Opcodes ..... 26  
Table 4-4 SCT Action Codes ..... 27  
Table 4-5 Definitions for the 512 Bytes. .... 27  
Table 4-6 Log Address Definition ..... 30  
Table 4-7 Identify Device Command..... 31



## 1.0 DESCRIPTION AND FEATURES

### 1.1 GENERAL DESCRIPTION

WD Purple Surveillance Storage is built for 24/7 always-on surveillance in high-definition security systems that use up to eight hard drives and up to 64 cameras. Exclusive AllFrame 4K™ technology works with ATA streaming to reduce error pixilation and video interruptions that occur when desktop hard drives are incorrectly used as storage in security systems.

### 1.2 Product Features

- **Serial ATA (SATA)** — Serial ATA (SATA) is the industry standard bus interface for hard drives. It is designed to replace Parallel ATA, and has many advantages including increased transfer rate, improved signal integrity, enhanced data protection, and hot plug support.
- **AllFrame 4K™** — All WD Purple™ drives are equipped with AllFrame 4K™ technology, which improves ATA streaming to help reduce frame loss, improve overall video playback, and increase the number of hard drive bays supported within a NVR. Help make your surveillance solution future-ready knowing that WD Purple™ drives are ready for ultra high definition cameras.
- **IntelliPower™** — A fine-tuned balance of spin speed, transfer rate and caching algorithms designed to deliver both significant power savings and solid performance. Additionally, these drives consume less current during startup allowing lower peak loads on systems as they are booted.
- **IntelliSeek™** — Calculates optimum seek speeds to lower power consumption, noise, and vibration.
- **Dynamic Fly Height Control** — Designed to compensate for head/media separation changes due to temperature and altitude. This feature adds video quality margins across temperature and altitude changes.
- **Perpendicular Magnetic Recording (PMR)** — With PMR technology the magnetization of each data bit is aligned vertically to the spinning disk, rather than longitudinally as has been the case in hard drive technology for decades. This enables more data on a given disk than is possible with conventional longitudinal recording, and provides a platform for future expansion of hard drive densities.
- **NoTouch™ Ramp Load Technology** — The recording head never touches the disk media ensuring significantly less wear to the recording head and media as well as better drive protection in transit.
- **Dual Stage Actuator Technology** — A head positioning system with dual-stage actuators that improves positioning accuracy over the data track(s). The primary stage provides course displacement; the secondary stage uses piezo electric motion to fine tune the head positioning to a higher degree of precision.
- **Advanced Format (AF)** — Technology adopted by WD and other drive manufacturers as one of multiple ways to continue growing hard drive capacities. AF is a more efficient media format that enables increased areal densities.
- **Native Command Queuing (NCQ)** — Performance of a random I/O workload can be improved through intelligent re-ordering of the I/O requests so they read/write to and from the nearest available sectors and minimize the need for additional disk revolutions or head actuator movement. This improvement can be achieved through Native Command Queuing (NCQ) , which is supported by these

hard drives.

- **Pre-emptive Wear Leveling (PWL)** — This WD feature provides a solution for protecting the recording media against mechanical wear. In cases where the drive is so busy with incoming commands that it is forced to stay in a same cylinder position for a long time, the PWL control engine initiates forced seeks so that disk lubricant maintains an even distribution and does not become depleted. This feature ensures reliability for applications that perform a high incidence of read/write operations at the same physical location on the disk.
- **Femto Slider** — These drives incorporate the femto slider form factor in which the read/write head is mounted on the small, lightweight femto slider which allows the head to move more quickly from track to track on the disk.
- **S.M.A.R.T. Command Transport (SCT)** — The SCT Command Transport feature set provides a method for a host to send commands and data to a device and for a device to send data and status to a host using log pages.
- **World Wide Name (WWN)** — The World Wide Name (WWN) defined in ATA/ATAPI-7 is a modification of the IEEE extended unique identifier 64 bit standard (EUI-64) and is comprised of three major components: naming authority, organizationally unique identifier (OUI) and serial number. WD's OUI is 0014EEh.
- **Reliability Features Set-Data Lifeguard™** — Representing WD's ongoing commitment to data protection, Data Lifeguard includes features that enhance the drive's ability to prevent data loss. Data Lifeguard data protection utilities include thermal management, an environmental protection system, and embedded error detection and repair features that automatically detect, isolate, and repair problem areas that may develop over the extended use of the hard drive. With these enhanced data reliability features, the drive can perform more accurate monitoring, error repair, and deliver exceptional data security.
- **Hot Plug Support** — SATA supports hot plugging (also known as "hot swapping"), the ability to swap out a failed hard drive without having to power down the system or reboot. This capability contributes to both data availability and serviceability without any associated downtime, making it a critical feature for extending SATA into enterprise applications.
- **Active LED Status** — The drive supports external LED requirements. It provides an activity LED output which is ON during command execution and OFF otherwise.
- **Fluid Dynamic Bearings (FDB)** — Bearing design that incorporates a layer of high-viscosity lubricant instead of ball bearings in the hard drive spindle motor. As an alternative to conventional ball bearing technology, FDB designs provide increased non-operational shock resistance, speed control, and improved acoustics.
- **Staggered Spin-Up** — SATA 3 Gb/s feature that allows the system to control whether the drive will spin up immediately or wait until the interface is fully ready (available for specific OEM configurations).
- **CacheFlow™** — WD's unique, multi-generation caching algorithm evaluates the way data is read from and written to the drive and adapts "on-the-fly" to the optimum read and write caching methods. CacheFlow minimizes disk seek operations and overheads due to rotational latency. CacheFlow supports sequential and random write cache. With write cache and other CacheFlow features, the user can cache both read and write data. The cache can hold multiple writes and collectively write them to the hard disk.

- **48-bit Logical Block Addressing (LBA)** — WD SATA drives support both 48-bit and 28-bit LBA and CHS-based addressing. LBA is included in advanced BIOS and operating system device drivers and ensures high capacity disk integration.
- **Power Management** — The drive supports the ATA and SATA power management command set, allowing the host to reduce the power consumption of the drive by issuing a variety of power management commands.
- **Self-Monitoring, Analysis, and Reporting Technology (S.M.A.R.T.)** — S.M.A.R.T. enables a drive's internal status to be monitored through diagnostic commands at the host level and during offline activities. S.M.A.R.T. devices employ data analysis algorithms that are used to predict the likelihood of some near-term degradation or fault conditions. When used with a S.M.A.R.T. application, the drive can alert the host system of a negative reliability status condition. The host system can then warn the user of the impending risk of data loss and recommend an appropriate action.
- **ATA Security** — The drive supports the ATA Security Mode Feature set. The ATA Security Mode feature set allows the user to create a device lock password that prevents unauthorized hard disk access even if the drive is removed from the host computer. The correct password must be supplied to the hard drive in order to access user data. Both the User and Master Password features are supported, along with the High and Maximum security modes. The Master Password Revision code is also supported. This feature varies by drive configuration and may not be available on all configurations.

## 2.0 SPECIFICATIONS

### 2.1 Performance Specifications

Rotational Speed	5400 RPM Class
Data Transfer Rate <sup>1</sup> - Buffer to Host - Host to/from Disk	6 Gb/s maximum 145 MB/s sustained (typical)
Buffer Size	64 MB
Error Rate - Unrecoverable	<1 in 10 <sup>14</sup> bits read
Spindle Start Time - From Power-on to Drive Ready - From Power-on to Rotational Speed	14.5s average 9s average
Spindle Stop Time	<15s average
Load/Unload Cycles (controlled unload at ambient condition)	300,000

<sup>1</sup> As used for buffer or cache, one megabyte (MB) = 1,048,576 bytes. As used for transfer rate or interface, megabyte per second (MB/s) = one million bytes per second, and gigabit per second (Gb/s) = one billion bits per second. Effective maximum SATA 6 Gb/s transfer rate calculated according to the Serial ATA specification published by the SATA-IO organization as of the date of this document. Visit [www.sata-io.org](http://www.sata-io.org) for details.

### 2.2 Physical Specifications

Specifications represented are of a typical production drive and may be subject to change or variation without notice.

Physical Specifications	WD30PURX/WD30PURZ/ WD30EVRX	WD20PURX/WD20PURZ/ WD20EVRX
Capacity <sup>1</sup>	3,000,592 MB	2,000,398 MB
Interface	SATA 6 Gb/s	SATA 6 Gb/s
Number of Disks	3	2
Data Surfaces	6	4
Number of Heads	6	4
Physical bytes per sector	4096	4096
Host bytes per sector	512	512
User Sectors per Drive	5,860,533,168	3,907,029,168
Servo Type	Embedded	Embedded
Recording Method	LDPC Target	LDPC Target

<sup>1</sup> As used for storage capacity, one megabyte (MB) = one million bytes, one gigabyte (GB) = one billion bytes, and one terabyte (TB) = one trillion bytes. Total accessible capacity varies depending on operating environment. As used for buffer or cache, one megabyte (MB) = 1,048,576 bytes. As used for transfer rate or interface, megabyte per second (MB/s) = one million bytes per second, and gigabit per second (Gb/s) = one billion bits per second. Effective maximum SATA 3 Gb/s transfer rate calculated according to the Serial ATA specification published by the SATA-IO organization as of the date of this document. Visit [www.sata-io.org](http://www.sata-io.org) for details.

### 2.2.1 Physical Dimensions

	English		Metric	
	Dimension	Tolerance	Dimension	Tolerance
Height	1.028 INCHES	MAX	26.1 MM	MAX
Length	5.787 INCHES	MAX	147.0 MM	MAX
Width	4.00 INCHES	±0.01 INCH	101.6 MM	±0.25 MM
Weight	1.40 POUNDS	±10%	0.635 KG	±10%

### 2.3 Mechanical Specifications

Figure 2-1 shows the mounting dimensions and locations of the screw holes for the drive.

Figure 2-1. Mounting Dimensions

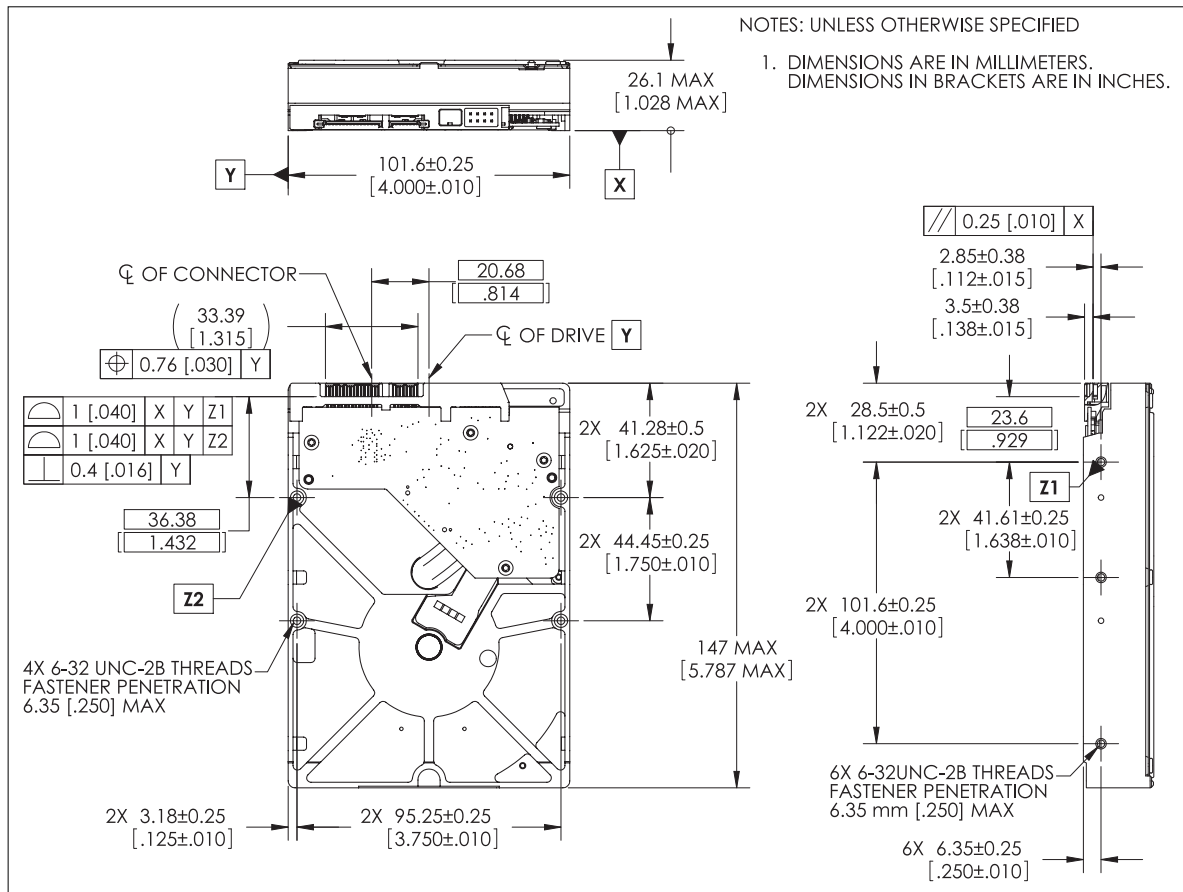

## 2.4 Electrical Specifications

### 2.4.1 Current Requirements and Power Dissipation

All values are typical (25°C, 5.0V, and 12V input). 3.3V Serial ATA power not utilized in this product.

Operating Mode	Mean Current		Power, Average
	12 VDC	5 VDC	
Spinup (max)	1.725A	-	23.6W
Read/Write	250 mA	280 mA	4.4W
Seek	400 mA	270 mA	6.2W

POWER MANAGEMENT COMMANDS			
Operating Mode	Mean Current		Power, Average
	12 VDC	5 VDC	
Idle	230 mA	260 mA	4.1W
Standby	7 mA	105 mA	0.6W
Sleep	7 mA	105 mA	0.6W

### 2.4.2 Input Voltage Requirements

The input voltage requirements are +5.0V  $\pm$  5% and +12.0V  $\pm$  10%.

### 2.4.3 Ripple

	+12 VDC	+5 VDC
Maximum Frequency	200 mV (double amplitude) 0-30 MHz	100 mV (double amplitude) 0-30 MHz

### 2.4.4 Power Connectors and Cables

#### SATA Connectors

For information on SATA data connectors, refer to the Serial ATA 1.0 specification available for download at [www.serialata.org](http://www.serialata.org).

At the time of this printing, there are no published standards for SATA power/mating connectors or power/data cable wire gauges.

#### Cabling Requirements for SATA

The SATA cable consists of four conductors in two differential pairs. The cable may also include drain wires to be terminated to the ground pins in the SATA cable receptacle connectors. See the SATA 1.0 specification for cable specifications. The cable's maximum length is one meter.



## 2.5 Environmental Specifications

### 2.5.1 Shock and Vibration

Table 2-1. Shock and Vibration

<b>Shock</b>	
Operating	30G, 2 ms (read/write) 65G, 2 ms (read)
Non-operating (2 ms)	250G
<i>Note: Half-sine wave, measured without shock isolation and without non-recoverable errors.</i>	
<b>Vibration</b>	
Operating	Linear: 20-300 Hz, 0.75G (0 to peak) Random: 0.004 g <sup>2</sup> /Hz (10-300 Hz)
Non-operating	Linear: 20-500 Hz, 4.0G (0 to peak) Random: 0.05 g <sup>2</sup> /Hz (10-300 Hz)
Sweep Rate	0.5 octave/minute minimum
<b>Drive Generated Vibration</b>	
Operating	0.2 gm-mm average with the drive in an unconstrained condition
<b>Rotational Shock Non-Operating</b>	
Amplitude	20K rad/sec <sup>2</sup>
Duration	2 ms

#### Operating Vibration

Drives are tested by applying a random excitation in each linear axis, one axis at a time. The drive incurs no physical damage and no hard errors while subjected to continuous vibration not exceeding the level listed in Table 2-1. Operating performance may degrade during periods of exposure to continuous vibration.

#### Non-Operating Vibration

*Note:* This specification applies to handling and transportation of unmounted drives.

Drives are tested by applying a random excitation in each linear axis, one axis at a time. The drive incurs no physical damage when subjected to continuous vibration not exceeding the level listed in Table 2-1.

#### Packaged Shock and Vibration

The shipping packaging is designed to meet the National/International Safe Transit Association (N/ISTA) standards for packaged products. The drive incurs no physical damage when subjected to the N/ISTA standards.

### 2.5.2 Temperature and Humidity

The system environment must allow sufficient air flow to limit maximum surface temperatures as defined. AFR can be affected by workload and operating temperature. See Section 2.6 on page 10 for further details.

Temperature & Humidity	
Operating	0°C to 65°C on the base casting (see Drive Base Casting Thermocouple Location below)
Humidity	5-95% RH non-condensing 37.7°C (maximum wet bulb)
Thermal Gradient	20°C/hour (maximum)
Humidity Gradient	20%/hour (maximum)
Non-operating Temperature	-40°C to 70°C on the base casting (see Drive Base Casting Thermocouple Location below)
Humidity	5-95% RH non-condensing 35°C (maximum wet bulb)
Thermal Gradient	30°C/hour (maximum)
Humidity Gradient	20%/hour (maximum)

### 2.5.3 Thermocouple Location

Component	Location
DRIVE BASE CASTING	#1, DRIVE BASE CASTING THERMOCOUPLE LOCATION

Figure 2-2. Drive Base Casting Thermocouple Location

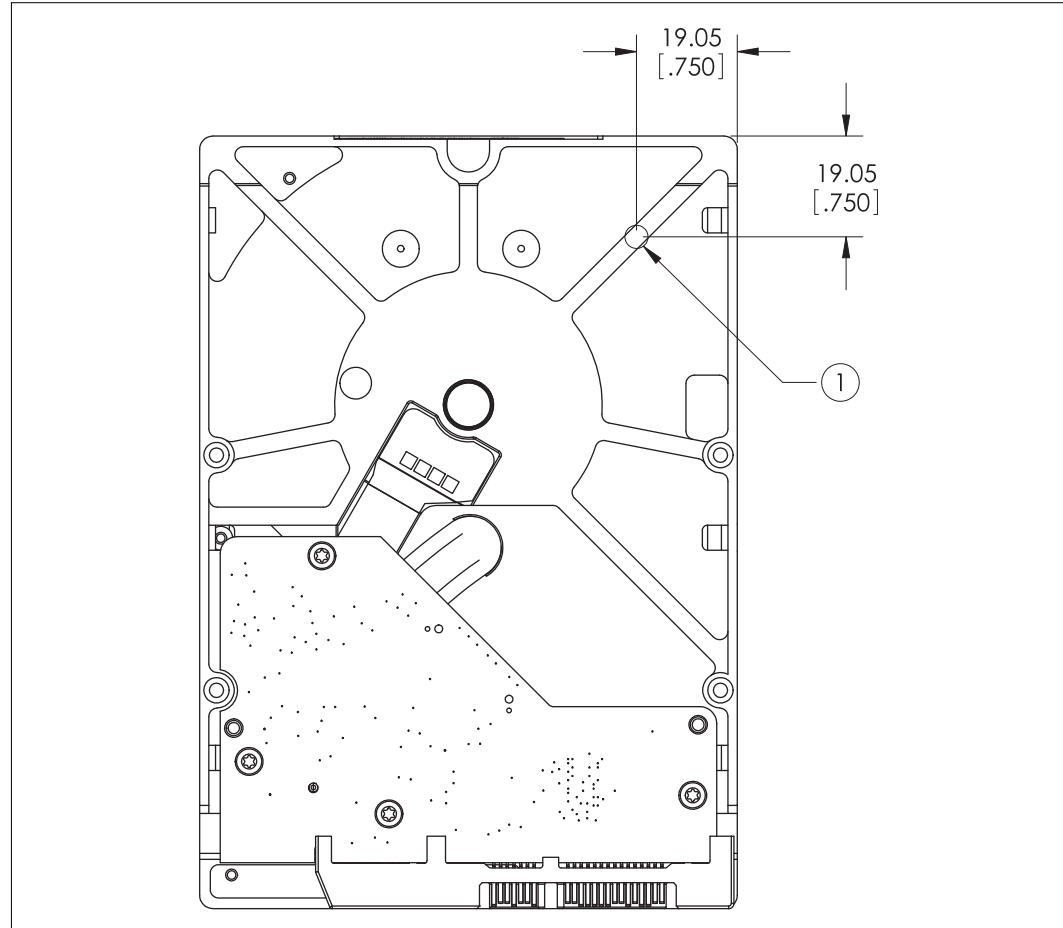

### 2.5.4 Cooling

If forced air cooling is required, the drive must be positioned to receive airflow from one or more fans as indicated in Forced Airflow Direction.

Figure 2-3. Forced Airflow Direction

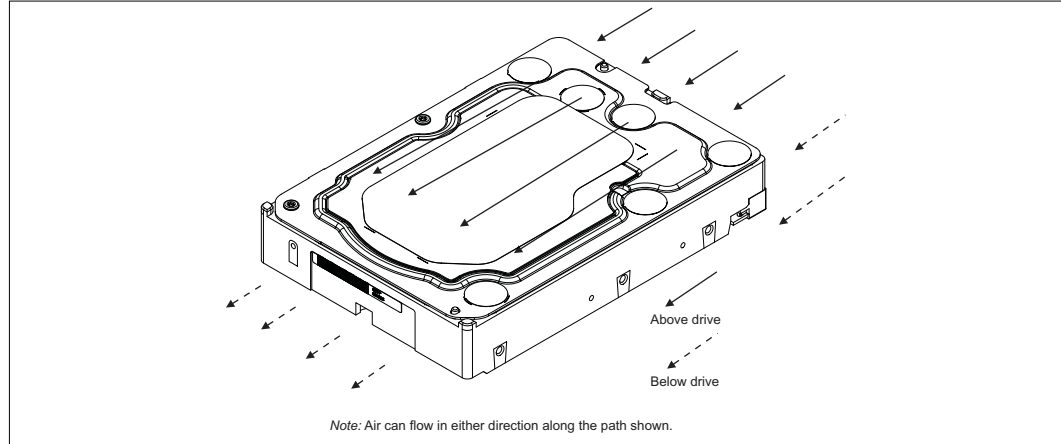

### 2.5.5 Atmospheric Pressure

Altitude	
Operating	-1,000 feet to 10,000 feet (-305M to 3,050M)
Non-operating	-1,000 feet to 40,000 feet (-305M to 12,200M)

### 2.5.6 Acoustics

TYPICAL SOUND POWER LEVEL MEASURED PER ECMA-74/ISO 7779	
Idle Mode (average dBA, no audible pure tones)	23
Seek Mode (average dBA)	24

### 2.5.7 RoHS (Restriction of Hazardous Substances)

WD complies with the Restriction of Hazardous Substances (RoHS) Directive 2011/65/EU of the European Parliament, which is effective in the EU beginning July 8, 2011. RoHS aims to protect human health and the environment by restricting the use of certain hazardous substances in new equipment, and consists of restrictions on lead, mercury, cadmium, and other substances.

## 2.6 Reliability Specifications and Characteristics

The average Annualized Failure Rate (AFR) calculations assume operation at nominal voltages, base casting temperature of 40°C, and the workload usage of a typical surveillance environment. Workload is defined as the number of bytes transferred by the user to/from the drive. If the system(s) that the drive is installed in are not capable of meeting the characteristics listed below, please use a WD drive that matches your system(s)' capability. Operating drives outside any of the reliability characteristics listed below will result in a higher AFR.

<i>Reliability Specification</i>	
Average AFR over the Limited Warranty Period	0.88%
<i>Reliability Characteristics</i>	
Base Casting Temperature	40°
Annual Power on Hours (POH)	<=8760
Annualized Workload Rate <sup>1</sup>	<=180 TB/YR

Annualized Workload Rate = TB transferred x (8760 / recorded power-on hours)

## 2.7 Device Plug Connector Pin Definitions

These drives interface with the host I/O bus via the SATA interface connection illustrated in Standard Factory Connectors below. The drive receives power from the SATA power connection or legacy ATA 4-pin power connector J3 in Standard Factory Connectors. Table 2-2 identifies the pin definitions of the SATA connectors and the corresponding signal names and signal functions.

Figure 2-4. Standard Factory Connectors

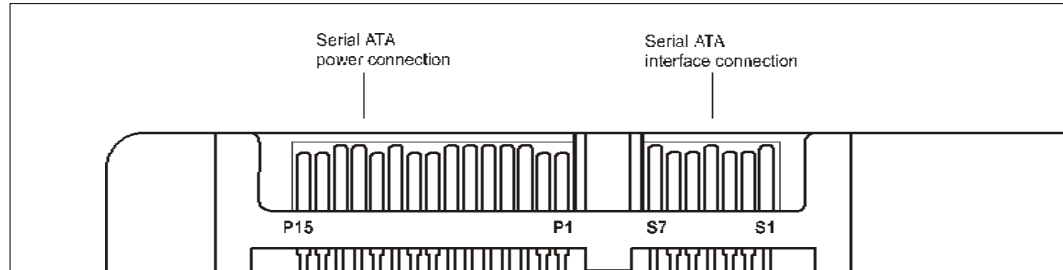

Table 2-2. Device Pin Connector Pin Definitions

SIGNAL SEGMENT	S1	Gnd	2nd mate
	S2	A+	Differential signal pair A from Phy
	S3	A-	
	S4	Gnd	2nd mate
	S5	B-	Differential signal pair B from Phy
	S6	B+	
	S7	Gnd	2nd mate
KEY AND SPACING SEPARATE SIGNAL AND POWER SEGMENTS			
POWER SEGMENT	P1	V <sub>33</sub>	3.3 V power, NC
	P2	V <sub>33</sub>	3.3 V power, NC
	P3	V <sub>33</sub>	3.3 V power, pre-charge, 2nd mate, NC
	P4	Gnd	1st mate, GROUND
	P5	Gnd	2nd mate, GROUND
	P6	Gnd	2nd mate, GROUND
	P7	V <sub>5</sub>	5V power, Precharge, 2nd mate
	P8	V <sub>5</sub>	5V power
	P9	V <sub>5</sub>	2nd mate, 5V power
	P10	Gnd	2nd mate, GROUND
	P11	ACT-	Activity LED- (O.C.)/Staggered Spin-up Disable Control
	P12	Gnd	1st mate, GROUND
	P13	V <sub>12</sub>	12 V power, pre-charge, 2nd mate
	P14	V <sub>12</sub>	12 V power
	P15	V <sub>12</sub>	12 V power

## 2.8 Agency Approvals

**PR1000M/PR1000A Regulatory Number (R/N):** 771945

These drives meet the standards of the following regulatory agencies:

- **Underwriters Laboratories:** Bi-National UL Standard CAN/CSA-C22.2 No. 60950/UL 60950-1. Standard for Safety of Information Technology Equipment, including Electrical Business Equipment (File E101559).
- **TUV NORD CERT GmbH:** IEC 60950-1 per EN 60950-1, Standard for Safety of Information Technology Equipment, including Electrical Business Equipment. IEC 60065. Standard of Safety for Audio, Video, and Similar Electronic Apparatus.
- **CE Compliance for Europe:** Complies with EN 55022: 2010 RF/ Conducted Emissions and EN 55024: 2010 Immunity requirements. Including EU Directive 2011/65/EU RoHS II requirements.
- **C-Tick Compliance for Australia:** Verified to comply with AS/NZS CISPR 22 for RF Emissions as required by the Australian Communications Authority.
- **Korean KC Mark:** Registered as a Class-B product with the South Korean Ministry of Information and Communication.
- **Taiwan BSMI EMI Certification:** Certified as a Class-B product with the Bureau of Standards Metrology and Inspection (BSMI).

## 2.9 Full Model Number Specification

Table 2-3 below provides a summary specification of the model number suffix for this product platform.

Table 2-3. Full Model Number Description

Model Number Format	ID	Product Brand	Description
WD30PURX-xxP6ZY0	P6Z	WD PURPLE	PR1000M 3TB Surveillance 64 MB SATA 6 Gb/s AF
WD20PURX-xxP6ZY0	P6Z	WD PURPLE	PR1000M 2TB Surveillance 64 MB SATA 6 Gb/s AF
WD30PURX-xxPFUY0	PFU	WD PURPLE	PR1000M 3TB SURVEILLANCE 64 MB SATA 6 Gb/s AF
WD20PURX-xxPFUY0	PFU	WD PURPLE	PR1000M 2TB SURVEILLANCE 64 MB SATA 6 Gb/s AF
WD30PURZ-xxGU6Y0	GU6	WD PURPLE	PR1000M 3TB SURVEILLANCE 64 MB SATA 6 Gb/s AF
WD20PURZ-xxGU6Y0	GU6	WD PURPLE	PR1000M 2TB SURVEILLANCE 64 MB SATA6 Gb/s AF
WD30EVRX-xxJT4Y0	JT4	WD PURPLE	PR1000M 3TB SURVEILLANCE 64 MB SATA6 Gb/s AF
WD20EVRX-xxJT4Y0	JT4	WD PURPLE	PR1000M 2TB SURVEILLANCE 64 MB SATA 6 Gb/s AF

### 3.0 PRODUCT FEATURES

- SATA 6 Gb/s
- AllFrame 4K™
- IntelliPower™
- IntelliSeek™
- Dynamic Fly Height Control
- Perpendicular Magnetic Recording (PMR)
- NoTouch™
- Dual Stage Actuator Technology
- Advanced Formatting
- Native Command Queuing (NCQ)
- Pre-Emptive Wear Leveling (PWL)
- Femto Slider
- S.M.A.R.T. Command Transport (SCT)
- World Wide Name (WWN)
- Reliability Features Set—Data Lifeguard™
- Hot Plug Support
- Active LED Status
- Fluid Dynamic Bearings (FDB)
- Staggered Spin-Up and Activity Indication (SATA Power Pin 11)
- CacheFlow™
- 48-bit Logical Block Addressing (LBA)
- Power Management
- Self-Monitoring, Analysis, and Reporting Technology (S.M.A.R.T.)
- Security Mode

### 3.1 SATA 6 Gb/s

SATA 6 Gb/s is the next generation interface for SATA hard drives. It adds to the functionality of the SATA 1.5 Gb/s interface with the following features:

- **Native Command Queuing (NCQ)** — server feature for performance in random I/O transaction environments. It aggregates many small random data transfers and allows the disk to reorder the commands in a sequential order for faster access.
- **Improved Power Management**— provides improved power management features including Host Initiated SATA Power Management (HIPM) and Device Initiated SATA Power Management (DIPM).
- **Staggered Spin-up** — allows the system to control whether the drive will spin up immediately or wait until the interface is fully ready before spinning up.
- **Asynchronous Signal Recovery (ASR)** — robustness feature that improves signal recovery.
- **Enclosure Services** — defines external enclosure management and support features.
- **Backplane Interconnect** — defines how to lay out signal line traces in a backplane.
- **Auto-activate DMA** — provides increased command efficiency through automated activation of the DMA controller.
- **Device Configuration Overlay (DCO)** — allows hiding of supported features via a SATA feature mask.

### 3.2 AllFrame 4K

All WD Purple™ drives are equipped with AllFrame 4K™ technology, which improves ATA streaming to help reduce frame loss, improve overall video playback, and increase the number of hard drive bays supported within a NVR. Help make your surveillance solution future-ready knowing that WD Purple™ drives are ready for ultra high definition cameras.

### 3.3 IntelliPower

A fine-tuned balance of spin speed, transfer rate and caching algorithms designed to deliver both significant power savings and solid performance. Additionally, these drives consume less current during startup allowing lower peak loads on systems as they are booted. Spin speed is reduced but optimized through a special blend of channel capability, electronics through-put capability, and mechanical resonances to achieve low power consumption.

### 3.4 IntelliSeek

WD's unique IntelliSeek technology proactively calculates an optimum seek speed to eliminate hasty movement of the actuator that produces noise and requires power, which is common in other drives. With IntelliSeek, the actuator's movement is controlled so the head reaches the next target sector just in time to read the next piece of information, rather than rapidly accelerating and waiting for the drive rotation to catch up. This smooth motion reduces power usage by more than 60 percent compared with standard drives, as well as quiets seek operation and lowers vibration.



### 3.5 Dynamic Fly Height Control

This feature is designed to compensate for head/media separation changes due to temperature and altitude. It adds video quality margins across temperature and altitude changes.

### 3.6 Perpendicular Magnetic Recording (PMR)

In perpendicular magnetic recording (PMR), the magnetization of each data bit is aligned vertically to the spinning disk, rather than longitudinally as has been the case in hard drive technology for decades. In longitudinal recording, as the bits become smaller and closer together, they experience an increasing demagnetizing field, much like two bar magnets that are placed end-to-end repel one another. A property of the media called coercivity must be increased to counteract the demagnetization to keep the bits stable under thermal fluctuations; otherwise data corruption may occur over time. Higher media coercivity has pushed the recording head write field to the limit of known materials.

In perpendicular recording, the adjacent bits attract instead of repel (as with bar magnets placed side by side,) creating more thermally stable bits. In addition, the media contains a magnetically soft underlayer (SUL) beneath the recording layer. This SUL allows a larger effective write field, thus higher coercivity media, enabling further increases in density. Lastly, because of the vertical orientation of the bits, the PMR recording layer tends to be thicker than that used for longitudinal recording, providing increased signal for the read heads. All of these benefits enable WD engineers to reliably pack more data on a given disk than is possible with conventional longitudinal recording.

### 3.7 NoTouch Ramp Load Technology

Parks the recording heads off the disk surface during spin up, spin down and when the drive is off. This ensures the recording head never touches the disk surface resulting in improved long term reliability due to less head wear, and improved non-operational shock tolerance.

### 3.8 Dual Stage Actuator Technology

A head positioning system with dual-stage actuators that improves positioning accuracy over the data track(s). The primary stage provides course displacement; the secondary stage uses piezo electric motion to fine tune the head positioning to a higher degree of precision.

### 3.9 Advanced Format (AF)

Advanced Format (AF) technology is adopted by WD and other drive manufacturers as one of multiple ways to continue growing hard drive capacities. AF is a more efficient media format that enables increased areal densities.

In AF, each physical sector is composed of eight 512 byte logical sectors, totalling 4096 bytes. WD is shipping AF drives as 512 Byte Emulated Devices until full operating system support for the AF host interface is available. 512 Byte Emulated Device drives are backward compatible with 512 byte sector accesses.

WD AF hard drives may require you to run the WD Align software utility after you install your operating system or partition and format the drive as a secondary drive. WD Align software aligns partitions on the AF drive to ensure it provides full performance for certain configurations. Go to [www.wdc.com/advformat](http://www.wdc.com/advformat) for important configuration and installation guidelines.

### 3.10 Native Command Queuing (NCQ)

These drives support Native Command Queuing. NCQ is a true Enterprise feature for environments such as database, Web servers, and e-mail servers.

Performance of a random I/O workload can be improved through intelligent re-ordering of the I/O requests so they read/write to and from the nearest available sectors and minimize the need for additional disk revolutions or head actuator movement. This improvement is achieved through Native Command Queuing (NCQ).

NCQ allows the drive to re-order read commands, thereby increasing random read IOPs. Additional NCQ features that can prove beneficial include a Write Cache disabled IOP increase and a queuing implementation built upon an existing, highly automated cache architecture. Queued reads in NCQ leverage the same re-ordering schemes used for write caching. The firmware design maintains the "order" of overlapping/colliding queued commands. NCQ is designed to excel in multi-threaded environments with high random I/O loads.

### 3.11 Pre-emptive Wear Leveling (PWL)

This WD feature provides a solution for protecting the recording media against mechanical wear. In cases where the drive is so busy with incoming commands that it is forced to stay in a same cylinder position for a long time, the PWL control engine initiates forced seeks so that disk lubricant maintains an even distribution and does not become depleted. This feature ensures reliability for applications that perform a high incidence of read/write operations at the same physical location on the disk.

### 3.12 Femto Slider

These drives incorporate the femto slider form factor in which the read/write head is mounted on the small, lightweight femto slider which allows the head to move more quickly from track to track on the disk. WD's femto heads enhance tracking and increase shock tolerance, producing a highly stable high-density drive platform.

### 3.13 S.M.A.R.T. Command Transport (SCT)

The SCT Command Transport feature set provides a method for a host to send commands and data to a device and for a device to send data and status to a host using log pages. Standard ATA commands may be interspersed with SCT commands, but SCT commands cannot be nested. SCT commands that do not require a subsequent data transfer operation are not interspersed with any ATA commands or each other.

The SCT Command Transport feature set provides a method for a host to send commands and data to a device and for a device to send data and status to a host using log pages. This capability is used to pass commands through a driver interface or a bridge where new or unknown commands may be filtered and not passed to the drive. SCT is also used for issuing commands that require more than 8 parameter bytes. ATA8-ACS provides detailed information on the usage and capabilities of SCT. The SCT feature set includes the following commands:

- Write Same
- Temperature Reporting

#### 3.13.1 Write Same

The Write Same command allows the host to erase the media, or write a pattern repeatedly across the media, with a minimum of data transfer from the host. The host can clear the entire media to zeros or a specific pattern by sending this command

with the pattern as a parameter—no data transfer is necessary. Write Same can write the entire media, or just a portion of the media. The host can monitor the progress of the Write Same by issuing SCT Status requests. This frees the host system to do other tasks while the media is being cleared.

### 3.13.2 Temperature Reporting

The SCT Temperature Reporting (SCT TR) feature allows a host system to access temperature information in the drive. The S.M.A.R.T. temperature value is reported within  $\pm 3^{\circ}\text{C}$  of the base casting temperature. This information can be used to control fans or adjust the usage of various system components to keep the drive within its normal operating temperature. Applications include Enterprise, Laptop, Desktop and Consumer Electronics. SCT TR reports the maximum and minimum sustained operating limits, warning level limits, and drive damage limits. In addition to reporting the limits, SCT TR returns the current drive temperature (a temperature history which the host can use to predict heating or cooling trends) and the maximum temperature achieved during the lifetime of the drive as well as the highest temperature achieved since the power was applied to the drive. Detailed information on this capability can be found in ATA8-ACS.

### 3.14 World Wide Name (WWN)

It has become a critical requirement that hard drives be uniquely identified by computer systems. This allows a drive to maintain its identity as it is transported from system to system or placed on a network. IEEE has defined a format for serial numbers that is widely recognized in the computing industry by adding World Wide Name (WWN) to ATA/ATAPI-7 in 2002.

The World Wide Name (WWN) defined in ATA/ATAPI-7 is a modification of the IEEE Extended Unique Identifier 64 bit standard (EUI-64) and is comprised of three major components: naming authority, organizationally unique identifier (OUI) and serial number. WD's OUI is 0014EEh.

### 3.15 Reliability Features Set

#### 3.15.1 Data Lifeguard™

Representing WD's ongoing commitment to data protection, Data Lifeguard includes features that enhance the drive's ability to prevent data loss. Data Lifeguard data protection utilities include thermal management, an environmental protection system, and embedded error detection and repair features that automatically detect, isolate, and repair problem areas that may develop over the extended use of the hard drive. With these enhanced data reliability features, the drive can perform more accurate monitoring, error repair, and deliver exceptional data security.

This self-tuning feature is performed during offline data collection scan. All user sectors on the hard drive are scanned during times of no activity from the host. Any sector determined to be written poorly (e.g., off-track), or that is difficult to recover (e.g., because of a developing media defect or thermal asperity), is marked for repair. Data Lifeguard actively guards your data, even if S.M.A.R.T. operations are disabled.

All WD drives are defect-free and low-level formatted at the factory. After prolonged use, any drive, including a WD drive, may develop defects. If you continue receiving data errors in any given file, use the Data Lifeguard Diagnostics utility to recover, relocate and rewrite the user data to the nearest spare sector and maintain a secondary defect list.

**CAUTION:** As with all format utilities, some options in the Data Lifeguard Diagnostics

utility will overwrite user data.

Download the latest versions of the Data Lifeguard Diagnostic and Data Lifeguard Tools programs at [support.wdc.com](http://support.wdc.com).

### 3.15.2 Thermal Management

The drive is designed with Thermal Management features for high reliability.

- **State-of-the-art mechanical design**—Mechanical design is optimized to reduce the drive's temperature. State-of-the-art thermal dissipation and windage design is employed.
- **Closed loop servo management**—Thermal management monitors the drive temperature and can control servo operations to maintain a stable operating temperature under high temperature conditions. This is a closed loop servo and thermal control system.
- **S.M.A.R.T. HDA Temperature Attribute**—The S.M.A.R.T. HDA Temperature Attribute is supported. The S.M.A.R.T. temperature value is reported within  $\pm 3^{\circ}\text{C}$  of the base casting temperature.
- **Ducted airflow**—Provides protection to the Read/Write element from heated air.

### 3.15.3 Internal Environmental Protection System

This dual filter system protects the inside environment of the drive from contamination. System features include:

- Dual Filtration System to ensure fast clean-up times
- Directed airflow to maximize mechanical cooling
- Increase casting surface area to maximize cooling
- Ducted air flow to protect Read Rite elements from heated air
- Breather filter located at low pressure area
- Enhanced heat dissipation

### 3.15.4 Recoverable Errors

A sector marked for repair is written back to the same location. The sector is then read several times to be sure that it was written correctly and that there is no media damage at its location (sector test). If the sector does not easily and consistently read correctly, the sector is then relocated with original data.

### 3.15.5 Unrecoverable Errors

If an unrecoverable error is found during the offline scan, the sector is marked. Future reads from this location will continue to perform full error recovery. However, the next write to this location will perform a sector test to be sure the media is not damaged, and the sector relocated if the sector test fails.

### 3.15.6 Self Test

Self Test is a quick way to determine the operation status of a drive. The following Self Tests are supported:

- **Quick Test:** Completes in less than two minutes.
- **Extended Test:** Tests all the critical subsystems of the drive.
- **Conveyance Test:** Quickly identifies issues caused by handling damage.
- **Selective Test:** Scans host-defined sections of the drive.

The test may be run to completion or be performed as a background task as the drive processes other commands from the host. The host may then poll the drive for runtime status and test results. Since the test is embedded in the drive's firmware, it is always available, requires no installation and can be faster and more effective than a software-based drive test.

### **3.15.7 ATA Error Logging**

ATA Error Logging provides an industry standard means to record error events and supporting information that is then accessible by the host. The event record includes the exact command that caused the failure, the response of the drive, the time of the event and information about the four commands immediately prior to the errant command. Error Logging can reliably and quickly determine whether a system problem is the result of a hard drive failure or other component malfunction. Error Logging retains total error count for the life of the drive and complete records for the last five errors.

### **3.15.8 Defect Management**

Every WD drive undergoes factory-level intelligent burn in, which thoroughly tests for and maps out defective sectors on the media before the drive leaves the manufacturing facility. Following the factory tests, a primary defect list is created. The list contains the cylinder, head, and sector numbers for all defects.

Defects managed at the factory are sector slipped. Grown defects that can occur in the field are mapped out by relocation to spare sectors on the inner cylinders of the drive.

## **3.16 Automatic Defect Retirement**

The automatic defect retirement feature automatically maps out defective sectors while reading or writing. If a defective sector appears, the drive finds a spare sector.

The following item is specific to automatic defect retirement on writes (write auto-relocation):

- Data is always written to disk (using automatic defect retirement if required) and no error is reported.

The following item is specific to automatic defect retirement on reads (read auto-relocation):

- When host retries are enabled, the drive will internally flag any unrecoverable errors (DAMNF or ECC). This flagging allows subsequent write commands to this location to relocate the sector only if the sector test fails.

### **3.16.1 Error Recovery Process**

The drive has five means of error recovery:

- ECC On-the-Fly
- Preamp Thermal Asperity (TA) Compensation
- Read/Write Retry Procedure
- Extended Read Retry Procedure

ECC On-the-Fly – If an ECC error occurs, the drive attempts to correct it on-the-fly without retries. Data can be corrected in this manner without performance penalty. The details of the correction algorithm appear in the next section.

Preamp Thermal Asperity Compensation – A Thermal Asperity (TA) is a baseline shift in the readback signal due to heating of the magnetoresistive stripe on the head as a result of physical contact with the disk or a particle. The preamp circuit has the ability to detect and compensate for thermal asperities. When an error cannot be corrected by ECC On-the-Fly, another retry is performed, where the preamp with its thermal asperity detection feature determines if the error is due to a thermal asperity. Once the preamp determines that the error is due to thermal asperity, preamp compensation is enabled. If preamp compensation alone is not enough to recover, then the channel performs a series of TA-specific recoveries.

Read/Write Retry Procedure – This retry procedure is used by all disk controller error types. If the procedure succeeds in reading or writing the sector being tried, then recovery is complete and the controller continues with the command. Each retry operation also checks for servo errors. The procedure ends when error recovery is achieved or when all possible retries have been attempted.

Extended Read Retry Procedure – This retry procedure tries combinations of positive/negative track offsets and data DAC manipulations to recover the data. This retry procedure applies only to read data recovery. The Read/Write Retry procedure performs the actual retry operation.

When an extended retry operation is successful, the controller continues with the command. The controller clears any changes in track offset or data DAC settings before the command continues.

### 3.17 Hot Plug Support

SATA supports hot plugging (also known as "hot swapping"), the ability to swap out a failed hard drive without having to power down the system or reboot. This capability contributes to both data availability and serviceability without any associated downtime, making it a critical feature for extending SATA into enterprise applications.

These WD hard drives support SATA 2.5 hot plugging only in systems where a SATA hard drive storage backplane is used.

The Serial ATA revision 2.5 specification requires staggered pins for both the hard drive and drive receptacles. Staggered pins mate the power signals in the appropriate sequences required for powering up the hot plugged device. These pins are also specified to handle in excess of the maximum allowed inrush current that occurs during drive insertion. SATA-compliant devices thus need no further modification to be hot pluggable and provide the necessary building blocks for a robust hot plug solution, which typically includes:

- Device detection even with power downed receptacles (typical of server applications).
- Pre-charging resistors to passively limit inrush current during drive insertion.
- Hot plug controllers to actively limit inrush current during drive insertion.

### 3.18 Active LED Status

The drive supports external LED requirements. It provides an activity LED output which is ON during command execution and OFF otherwise.

The drive strength of this open Drain Drive Active signal is that it can sink 12mA to 0.4V Max. It is 5V tolerant, meaning that the external LED may be driven from +5V or +3.3V so long as the Host system provides a series resistor to limit the LED current to the lower of 12mA or the rated operating current of the LED. As an example with +5V and a 2 volt forward drop across a 10mA LED, a 300 Ohm 5% 1/16W resistor would

be suitable. In the case of a 3.3V supply for the same LED, the resistor would be 130 Ohm 5% 1/16W.

The pin corresponding to P11 shall be used for Active LED (see "Device Plug Connector Pin Definitions" on page 10).

### **3.19 Fluid Dynamic Bearings (FDB)**

Bearing design that incorporates a layer of high-viscosity lubricant instead of ball bearings in the hard drive spindle motor. As an alternative to conventional ball bearing technology, FDB designs provide increased non-operational shock resistance, speed control, and improved acoustics.

### **3.20 Staggered Spinup and Activity Indication (SATA Power Pin 11)**

Note: This feature is available for specific OEM configurations.

SATA device power connector pin 11 (see "Standard Factory Connectors" on page 10) is defined as a means by the host to DISABLE staggered spinup and it may also be used by the device to provide the host with an activity indication. According to the SATA spec, "Staggered Spin-up Disable and Activity Signal shall not be enabled at the same time."

#### **3.20.1 Staggered Spinup**

When multiple disks are installed in an enclosure, it is desirable to provide a simple mechanism by which a subsystem controller can sequence hard drive initialization to minimize the current load presented during power up. Staggered spinup provides this mechanism by preventing the hard drives from spinning up until after successful PHY initialization (i.e., after PHY enters DP7:DR\_Ready state).

Staggered spinup is only applicable during initial power-up. If a drive is spun down using ATA commands—as a result of having been placed in Standby or Sleep power modes, for example—the drive shall spin up following the rules that govern spinup from low power modes described in ATA/ATAPI-6 or later.

#### **3.20.2 Activity Indication**

The host controller through SATA power pin 11 may access storage device status and activity. The signal provided by the device for activity indication is a low-voltage low-current signal. It is not suitable for directly driving an LED. A buffer circuit external to the device must be employed to drive the LED. The activity signal is based on an open-collector or open-drain active low driver. The device shall tolerate the activity signal being shorted to ground.

### **3.21 CacheFlow™**

CacheFlow is WD's unique, multi-generation disk caching system. It incorporates read cache with write cache.

WD designed CacheFlow to obtain maximum performance with today's most popular operating systems and applications. CacheFlow increases performance over prior caching algorithms by increasing the number of times that requested data is in the cache. This reduces the number of host commands that require actual media access thereby improving overall drive performance.

Typical applications perform a variety of access patterns, such as random, sequential, and repetitive. CacheFlow is designed to dynamically adapt to the changes in access patterns that occur during the course of application execution.

Random mode is the default operational mode for CacheFlow. Once CacheFlow detects a sequential access pattern, it leaves random mode. CacheFlow also performs predictive read operations to increase the probability that data requested in future commands already exists in the cache.

CacheFlow partitions the buffer into multiple segments to allow for the fact that applications may access multiple non-contiguous areas on the disk. CacheFlow tracks the amount of valid data in each segment and controls the deallocation of segments to maximize drive performance.

**3.21.1 Write Cache**

CacheFlow is designed to improve both single and multi-sector write performance by reducing delays caused by seek time and rotational latency.

The write cache adaptively detects random and sequential access patterns during application execution.

If a defective sector is found during a write cache operation, that sector is automatically relocated before the write occurs.

**3.21.2 Read Cache**

CacheFlow implements a multiple segment read cache. Cache segments are assigned to read commands as they are received from the host.

Each read segment consists of pre and post read sectors in addition to the host-requested sectors. This maximizes the amount of cache data in the drive's buffer, thereby increasing the likelihood of cache hits and improving overall performance.

**3.22 48-bit Logical Block Addressing (LBA)**

The 48-bit Address feature set allows devices with capacities up to approximately 281 tera sectors or approximately 144 peta bytes. In addition, the number of sectors that may be transferred by a single command are increased by increasing the allowable sector count to 16 bits.

48-bit Address					
Bits (47:40)	Bits (39:32)	Bits (31:24)	Bits (23:16)	Bits (15:8)	Bits (7:0)
LBA HIGH (EXP)	LBA MID (EXP)	LBA LOW (EXP)	LBA HIGH	LBA MID	LBA LOW

16-bit Sector Count	
Bits (15:8)	Bits (7:0)
SECTOR COUNT (EXP)	SECTOR COUNT

**3.23 Power Management**

This drive supports the ATA power management commands that lower the average power consumption of the hard drives. For example, to take advantage of the lower power consumption modes of the drive, an energy efficient host system could implement a power management scheme that issues a Standby Immediate command when a host resident disk inactivity timer expires. The Standby Immediate command causes the drive to spin down and enter a low-power mode. Subsequent disk access commands would cause the drive to spin up and execute the new command. To



avoid excessive wear on the drive due to the starting and stopping of the HDA, set the host's disk inactivity timer to no shorter than ten minutes.

The drive also supports the SATA power management feature that lowers the average power consumption of the SATA interface.

### **3.24 Self-Monitoring, Analysis, and Reporting Technology (S.M.A.R.T.)**

S.M.A.R.T. helps you monitor a drive's internal status through diagnostic commands at the host level.

The drive monitors Read Error Rate, Start/Stop Count, Re-allocated Sector Count, Seek Error Rate, Power-on Hours Count, Spin-up Retry Count, Drive Calibration Retry Count, Drive Power Cycle Count, Offline Scan Uncorrectable Sector Count, Ultra ATA CRC Error Rate, Multi-zone Error Rate, Spin-up Time, Relocation Event Count, and Current Pending Sector Count. The hard drive updates and stores these attributes in the reserved area of the disk. The drive also stores a set of attribute thresholds that correspond to the calculated attribute values. Each attribute threshold indicates the point at which its corresponding attribute value achieves a negative reliability status.

### **3.25 SECURITY MODE**

The Security Mode feature set allows the user to create a device lock password that prevents unauthorized hard drive access even if the drive is removed from the computer. This feature varies by drive configuration and may not be available on all configurations.

#### **3.25.1 Master and User Passwords**

The manufacturer/dealer can set a master password using the Security Set Password command, without enabling the device lock function. The user password should be given or changed by a system user.

Master Password Identifier is supported and set to a default value of 00FE. If a Master Password is set via a Security Set Password Command, a valid Master Password Revision code value of 0001h – FFFEh must be used. A Master Password Identifier of 0000h is ignored.

When the master password is set, the drive does *not* enable the device lock function. When the user password is set, the drive enables the device lock function, and the drive is locked after the next power on reset or hard reset.

#### **3.25.2 Security Levels**

High - If High level security is set and the user password is forgotten, the master password can be used to unlock the drive and access the data.

Maximum - If Maximum level security is set and the user password is forgotten, data access is impossible. Only the master password with a Security Erase Unit command can unlock the drive when the device lock function is enabled and the user password has been forgotten. When the Security Erase Unit command is used to unlock the drive, all user data is erased.

## 4.0 ATA COMMAND SET

### 4.1 Host Interface Commands

#### 4.1.1 ATA-8 Commands

Table 4-1 lists the hexadecimal codes specific to each ATA-8 command supported by these hard drives. Refer to the D1699 ATA8-ACS specification for full details on each command.

Table 4-1. ATA-8 Command Opcodes

COMMAND	HEX OPCODE
CHECK POWER MODE	E5
DEVICE CONFIGURATION OVERLAY	B1
DOWNLOAD MICROCODE	92
EXECUTE DEVICE DIAGNOSTIC	90
FLUSH CACHE	E7
FLUSH CACHE EXT	EA
IDENTIFY DEVICE	EC
IDLE	E3
IDLE IMMEDIATE	E1
NOP	00
READ BUFFER	E4
READ DMA	C8
READ DMA EXT	25
READ FPDMA QUEUED	60
READ LOG EXT	2F
READ LOG DMA EXT	47
READ MULTIPLE	C4
READ MULTIPLE EXT	29
READ NATIVE MAX ADDRESS	F8
READ NATIVE MAX ADDRESS EXT	27
READ SECTOR(S)	20
READ SECTORS(S) EXT	24
READ VERIFY SECTOR(S) EXT	42
READ VERIFY SECTORS(S)	40
S.M.A.R.T.	B0
SECURITY DISABLE PASSWORD	F6
SECURITY ERASE PREPARE	F3
SECURITY ERASE UNIT	F4
SECURITY FREEZE LOCK	F5
SECURITY SET PASSWORD	F1
SECURITY UNLOCK	F2

COMMAND	HEX OPCODE
SET FEATURES	EF
SET MAX	F9
SET MAX ADDRESS EXT	37
SET MULTIPLE	C6
SLEEP	E6
STANDBY	E2
STANDBY IMMEDIATE	E0
WRITE BUFFER	E8
WRITE DMA	CA
WRITE DMA EXT	35
WRITE FPDMA QUEUED	61
WRITE LOG EXT	3F
WRITE LOG DMA EXT	57
WRITE MULTIPLE	C5
WRITE MULTIPLE EXT	39
WRITE SECTOR(S)	30
WRITE SECTOR(S) EXT	34
WRITE UNCORRECTABLE EXT	45

#### 4.1.2 SATA Commands

Table 4-2 lists the hexadecimal codes specific to each SATA command supported by these hard drives. Refer to the SATA specification for full details on each command.

Table 4-2. SATA Command Opcodes

COMMAND	HEX OPCODE
READ FPDMA QUEUED	60
WRITE FPDMA QUEUED	61

#### 4.1.3 Obsolete Commands

Table 4-3 lists the hexadecimal codes specific to each obsolete command supported by these hard drives.

Table 4-3. Obsolete Command Opcodes

COMMAND	HEX OPCODE
INITIALIZE DEVICE PARAMETERS	91
READ LONG	22
RECALIBRATE	10
SEEK	70
WRITE LONG	32

#### 4.1.4 SCT Commands

SCT commands provide capabilities not covered in ATA/ATAPI-7 for commands that do not fit the ATA command delivery model. Some SCT commands report completion when the command begins execution. Execution progress for these commands may be checked by requesting SCT status. For instance, the host can track the progress of a Write Same command by issuing a status request once per minute. See ATA8-ACS for a full description of SCT.

Table 4-4. SCT Action Codes

ACTION CODE	DESCRIPTION
0000H	RESERVED
0001H	OBSOLETE
0002H	WRITE SAME
0004H	FEATURES CONTROL
0005H	SCT DATA TABLES
0006H	VENDOR SPECIFIC
0007H	SCT BIST
C000H	FFFFH VENDOR SPECIFIC

#### 4.2 S.M.A.R.T. (Boh)

The S.M.A.R.T. command provides access to attribute values, S.M.A.R.T. status, and other S.M.A.R.T. information. These commands can be used for logging and reporting purposes, and for accommodating special user needs.

Prior to writing the S.M.A.R.T. command to the Command Register, the host must write key values into the LBA Mid and LBA High Registers (4Fh, C2h) or the command will be aborted and an error will be reported.

The S.M.A.R.T. command has several sub-commands that are selectable via the Features Register when the host issues the S.M.A.R.T. command. To select a sub-command, the host must write the appropriate sub-command code to the Features Register before issuing the S.M.A.R.T. command. The sub-commands and their respective codes are listed below. For more detailed information on executing S.M.A.R.T. commands, see the ATA-7 specification.

##### 4.2.1 Read Attribute Values Sub-Command

This command returns a sector of data with the drive's S.M.A.R.T. data structure.

Table 4-5. Definitions for the 512 Bytes.

BYTE	VALUE	DESCRIPTION
0 - 1	0001H	S.M.A.R.T. Data Structure Revision
2 -361	XX	S.M.A.R.T. Attribute Data
135 - 361	XX	S.M.A.R.T. Attribute Data
362	XX	Offline data collection status 0Xh OL disabled 8Xh OL enabled X0h scan not run X2h scan complete X4h scan suspended X5h scan aborted
363	XX	Self-Test execution status byte.

BYTE	VALUE	DESCRIPTION
		<p>00h The previous self-test routine completed without error or no self-test has ever been run</p> <p>01h The self-test routine was aborted by the host</p> <p>02h The self-test routine was interrupted by the host with a hard or soft reset</p> <p>03h A fatal error or unknown test error occurred while the device was executing its self-test routine. The device was unable to complete the self-test routine.</p> <p>04h The previous self-test completed having a test element that failed. The test element that failed is not known.</p> <p>05h The previous self-test completed having a test element that failed. The electrical element of the test failed.</p> <p>06h The previous self-test completed having a test element that failed. The servo (and/or seek) test element of the test failed.</p> <p>07h The previous self-test completed having a test element that failed. The read element of the test failed.</p> <p>08h The previous self-test completed having a test element that failed. The element damage is suspected to be caused by handling.</p> <p>09-0Eh Reserved</p> <p>0Fh Self-test routine in progress</p>
364 - 365	XX	Total time in seconds to complete offline data collection activity
366	XX	Reserved
367	07BH	<p>Offline data collection capability. Bits are as follows:</p> <p>0 1 = Offline Immediate Command supported</p> <p>1 1 = Auto Offline enable\disable command supported</p> <p>2 0 = Offline will suspend on and will resume after host command</p> <p>3 1 = Offline read scan implemented</p> <p>4 1 = DST Short and Extended tests supported</p> <p>5 1 = DST Conveyance test supported</p> <p>6-7 0 - Reserved</p>
368 - 369	0003H	<p>S.M.A.R.T. Capability. Bits are as follows:</p> <p>0 1 = The device saves SMART data prior to going into a power saving mode</p> <p>1 1 = Device complies with SMART data autosave after an event</p> <p>2-15 Reserved</p>
370	01H	<p>Error logging capability. Bits are as follows:</p> <p>0 1 = Error logging supported</p> <p>1 Reserved</p>
371	XX	Reserved
372	XX	Short self-test routine completion time in minutes
373	XX	Extended self-test routine completion time in minutes
374	XX	Conveyance self-test routine completion time in minutes
375 - 510	XX	Reserved
511	XX	Checksum

### 4.2.2 Supported Attributes

The drive supports the following attributes.

Attribute	Attribute ID Number	Pre-Failure/Advisory Bit (Status Flags bit 0) <sup>1</sup>
Read Error Rate	1	PRE-FAILURE
Spin-up Time	3	PRE-FAILURE
Start/Stop Count	4	ADVISORY
Re-allocated Sector Count	5	PRE-FAILURE
Seek Error Rate	7	ADVISORY
Power-on Hours Count	9	ADVISORY
Spin-up Retry Count	10	ADVISORY
Drive Calibration Retry Count	11	ADVISORY
Drive Power Cycle Count	12	ADVISORY
Emergency Retract Cycles	192	ADVISORY
Load/Unload Cycles	193	ADVISORY
HDA Temperature <sup>2</sup>	194	ADVISORY
Relocation Event Count	196	ADVISORY
Current Pending Sector Count	197	ADVISORY
Offline Scan Uncorrectable Sector Count	198	ADVISORY
Ultra ATA CRC Error Rate	199	ADVISORY
Multi-zone Error Rate	200	ADVISORY
<sup>1</sup> Status bits are typical but may vary. <sup>2</sup> See "Temperature Reporting" on page 17 for a better mechanism.		

Attributes that use the Pre-Failure/Advisory Bit Set can predict potential future degrading or faulty conditions. Attributes with the Failure/Advisory Bit Clear are used for informational purposes only, they do not indicate impending drive failure.

The S.M.A.R.T. data saving process is a background task. After a pre-determined idle period, the self-monitoring data is automatically saved to the disk.

### 4.2.3 Read Log Sector

There are several logs that can be read with the S.M.A.R.T. Read Log Sector sub-command. The LBA Low Register indicates the log sector to be returned.

Table 4-6. Log Address Definition

Log Address	Log Name	Feature Set	R/W	Access
00H	Log directory	ExtLog	RO	GPL, SL
01H	Summary Log	SMART	RO	SL
02H	Comprehensive SMART error log	SMART	RO	SL
03H	Extended Comprehensive SMART error log	ExtLog	RO	GPL
04H	Device Statistics	N/A	RO	GPL, SL
05H	Reserved	Reserved	Reserved	
06H	SMART self-test log	SMART	RO	SL
07H	Extended SMART self-test log	ExtLog	RO	GPL
08H	Reserved	Reserved	Reserved	
09H	Selective self-test log	SMART	R/W	SL
0AH-0FH	Reserved	N/A	Reserved	
10H	NCQ Command Error	NCQ	RO	GPL
11H	SATA PHY Counters	ExtLog	RO	GPL
12H-17H	Reserved for Serial ATA	N/A	Reserved	
18H-1FH	Reserved	N/A	Reserved	
20H	Obsolete			
21H	Write Stream Error Log	Streaming	RO	GPL
22H	Read Stream Error Log	Streaming	RO	GPL
23H	Obsolete			
24H-7FH	Reserved	N/A	Reserved	
80H-9FH	Host vendor specific	SMART / Ext-Log	R/W	GPL, SL
A0H-BFH	Device vendor specific	SMART / Ext-Log	VS	GPL, SL
C0H-EFH	Reserved	Reserved	Reserved	
E0H	SCT Command/Status	N/A	R/W	GPL, SL
E1H	SCT Data Transfer			GPL, SL
E2H-FFH	Reserved	Reserved	Reserved	

RO - Read Only  
R/W - Read / Write  
SMART - Supported by Boh command code.  
ExtLog - Supported by 2Fh/3Fh command code.  
VS - Vendor Specific  
SCT - SMART Command Transport



### 4.3 Identify Device (ECh)

The Identify Device command transfers 512 bytes of data that specify the drive's parameters. Table 4-7 lists the parameters read by the host

Table 4-7. Identify Device Command

WORD	FIELD DESCRIPTION	VALUE
0	General Configuration	427AH
1	Obsolete	0
2	Specific Configuration	XXXX
3	Obsolete	0
4-5	Retired	0
6	Obsolete	0
7-8	Reserved for assignment by the CompactFlash™ Association	0
9	Retired	0
10-19	Serial Number (ATA String)	WDNNNNNNNN
20-21	Retired	0
22	Obsolete	0
23-26	Firmware Revision (ATA String)	NNNN
27-46	Model Numbers (ATA String)	“WDC WD30PURX-NNN-NNN” “WDC WD20PURX-NNN-NNN” “WDC WD30PURZ-NNN-NNN” “WDC WD20PURZ-NNN-NNN” “WDC WD30EVRX-NNN-NNN” “WDC WD20EVRX-NNN-NNN”
47	READ/WRITE MULTIPLE support Bit 15-8: 80h Bit 7-0: 00h: Reserved 01h-FFh = Maximum number of logical sectors that shall be transferred per DRQ data block on READ/WRITE MULTIPLE commands	8010H
48	Trusted Computing feature set options Bit 15: Shall be cleared to zero Bit 14: Shall be set to one Bit 13-1: Reserved for the Trusted Computing Group Bit 0: If set, Trusted Computing feature set is supported	0
49	Capabilities Bit 15-14: Reserved for the IDENTIFY PACKET DEVICE command. Bit 13: If set, Standby timer values as specified in this standard are supported. 0 = Standby timer values shall be managed by the device Bit 12: Reserved for the IDENTIFY PACKET DEVICE command Bit 11: If set, IORDY supported Bit 10: If set, IORDY may be disabled Bit 9: If set, LBA supported Bit 8: If set, DMA supported Bit 7-2: Reserved Bit 1: Current Long Physical Alignment Setting	2F00H

50	Capabilities Bit 15: Shall be cleared to zero. Bit 14: Shall be set to one. Bit 13-2: Reserved. Bit 1: Obsolete Bit 0: Shall be set to one to indicate a device specific Standby timer value minimum	4001H
51-52	Obsolete	0
53	Additional Words Valid Bit 8-15: Free-fall Control Sensitivity 00h = Vendor's recommended setting 01h-FFh = Sensitivity level. A larger number is a more sensitive setting. Bit 7-3: Reserved Bit 2: If set, the fields reported in word 88 are valid Bit 1: If set, the fields reported in words 70-64 are valid Bit 0: Obsolete	0007H
54-58	Obsolete	0
59	Current Blocking Factor Bit 15: 1=The BLOCK ERASE EXT command is supported Bit 14: 1= The OVERWRITE EXT command is supported Bit 13: 1=The CRYPTO Scramble EXT command is supported Bit 12: 1=The Sanitize feature set is supported Bit 9-11 Reserved Bit 8: 1=Multiple local sector setting is valid Bit 0-7: Current setting for number of logical sectors that shall be transferred per DRQ data block on READ/WRITE Multiple commands	XXH
60-61	Total number of user addressable logical sectors for 28 bit commands (DWord)	0FFFFFFFH
62	Obsolete	0
63	Multi-Word DMA Transfer Mode Supported Bit 15-11: Reserved Bit 10: If set, Multiword DMA mode 2 is selected Bit 9: If set, Multiword DMA mode 1 is selected Bit 8: If set, Multiword DMA mode 0 is selected Bit 7-3: Reserved Bit 2: If set, Multiword DMA mode 2 Bit 1: If set, Multiword DMA mode 1 Bit 0: If set, Multiword DMA mode 0	XX07H
64	Advanced PIO Modes Supported Bits 0-7: PIO Modes supported	0003H
65	Min. Multi-Word DMA Transfer Cycle Time (ns) Bit 15-0: Cycle time in nanoseconds	120
66	Manufacturer Recommended Multi-Word DMA Cycle Time Bit 15-0: Cycle time in nanoseconds	120
67	Min. PIO Transfer Cycle Time without flow control Bit 15-0: Cycle time in nanoseconds	120
68	Min. PIO Transfer Cycle Time with IORDY flow control Bit 15-0: Cycle time in nanoseconds	120

69	<p>Additional Supported</p> <p>Bit 15: If set, CFast Specification Support</p> <p>Bit 14: If set, Deterministic data in trimmed LBA range(s) is supported</p> <p>Bit 13: If set, Long Physical Sector Alignment Error Reporting Control is supported</p> <p>Bit 12: If set, DEVICE CONFIGURATION IDENTIFY DMA and DEVICE CONFIGURATION SET DMA are supported</p> <p>Bit 11: If set, READ BUFFER DMA is supported</p> <p>Bit 10: If set, WRITE BUFFER DMA is supported</p> <p>Bit 9: If set, SET MAX SET PASSWORD DMA and SET MAX UNLOCK DMA are supported</p> <p>Bit 8: If set, DOWNLOAD MICROCODE DMA is supported</p> <p>Bit 6: If set, Optional ATA device 28-bit commands supported</p> <p>Bit 7: If set, Reserved for IEEE 1667</p> <p>Bit 5: If set, Trimmed LBA range(s) returning zeroed data is supported</p> <p>Bit 4: If set, Device Encrypts All User Data</p> <p>Bit 3: If set, Extended Number of User Addressable Sectors is supported</p> <p>Bit 2-0: Reserved</p>	0
70	Reserved	0
71-74	Reserved for the Identify Packet Device command	0
75	<p>Queue Depth</p> <p>Bit 15-5: Reserved</p> <p>Bit 4-0: Maximum queue depth - 1</p>	001FH
76	<p>Serial ATA Capabilities</p> <p>Bit 15-13: Reserved</p> <p>Bit 12: Supports Native Command Queuing priority information</p> <p>Bit 11: Supports Unload while NCQ commands outstanding</p> <p>Bit 10: Supports Phy event counters</p> <p>Bit 9: Supports receipt of host-initiated interface power management requests</p> <p>Bit 8: Supports Native Command Queuing (NCQ)</p> <p>Bit 7-3: Reserved for future Serial ATA signaling speed grades</p> <p>Bit 2: 1 = Supports Serial ATA Gen2 signaling speed (3 Gb/s)</p> <p>Bit 1: 1 = Supports Serial ATA Gen1 signaling speed (1.5 Gb/s)</p> <p>Bit 0: Shall be cleared to zero</p>	1001 0111 0000 0110B 970EH
77	Reserved for Serial ATA	0002H
78	<p>Serial ATA Features Supported</p> <p>Bit 7-15: Reserved for Serial ATA</p> <p>Bit 6: If set, device supports software settings preservation</p> <p>Bit 5: Reserved for Serial ATA</p> <p>Bit 4: If set, device supports in-order data delivery</p> <p>Bit 3: If set, device supports initiating power management</p> <p>Bit 2: If set, device supports DMA Setup Auto-activation</p> <p>Bit 1: If set, device supports non-zero buffer offsets</p> <p>Bit 0: Cleared to zero</p>	0000 0000 0100 1000 0044H
79	<p>Serial ATA Features Enabled</p> <p>Bits 7-15: Reserved for Serial ATA</p> <p>Bit 6: If set, software settings preservation enabled</p> <p>Bit 5: Reserved for Serial ATA</p> <p>Bit 4: If set, In-order data delivery enabled</p> <p>Bit 3: If set, device initiated power management enabled</p> <p>Bit 2: If set, DMA Setup Auto-activation enabled</p> <p>Bit 1: If set, non-zero buffer offsets enabled</p> <p>Bit 0: Cleared to zero</p>	0000 0000 0X0X XXX0B
80	<p>Major Version Number</p> <p>Bit 15-10: Reserved</p> <p>Bit 9: if set, supports ACS-2</p> <p>Bit 8: if set, supports ATA8-ACS</p> <p>Bit 7: if set, supports ATA/ATAPI-7</p> <p>Bit 6: if set, supports ATA/ATAPI-6</p> <p>Bit 5: if set, supports ATA/ATAPI-5</p> <p>Bit 4-1: Obsolete</p> <p>Bit 0: Reserved</p>	03FEH

81	Minor Version Number	0000H
82	Command and feature sets supported Bit 14: If set, NOP command supported Bit 13: If set, Read buffer command supported Bit 12: If set, Write buffer command supported Bit 11: Obsolete Bit 10: If set, Host Protected Area Feature Set supported Bit 9: If set, Device Reset command supported Bit 8: If set, Service interrupt supported Bit 7: If set, Release interrupt supported Bit 6: If set, look-ahead supported Bit 5: If set, Write Cache supported Bit 4: Cleared to 0 to indicate that the PACKET feature set is not supported. Bit 3: If set, mandatory Power Management Feature Set supported Bit 2: Obsolete Bit 1: If set, Security Feature Set supported Bit 0: If set, SMART Feature Set supported	0111 0100 0110 1011B 746BH
83	Command Set Supported Bit 15: Shall be cleared to 0 Bit 14: Shall be set to 1 Bit 13: If set, Flush Cache EXT command supported Bit 12: If set, mandatory Flush Cache command supported Bit 11: If set, DCO feature set supported Bit 10: If set, 48-bit Address Feature Set supported Bit 9: Not supported Bit 8: If set, Set Max Security Extension supported Bit 7: Reserved Bit 6: If set, Set Features subcommand required to spin-up after power-up Bit 5: If set, Power-Up In Standby feature set supported Bit 4: Obsolete Bit 3: If set, Advanced Power Management feature set supported Bit 2: If set, CFA feature set supported Bit 1: If set, Read/Write DMA Queued supported Bit 0: If set, Download Microcode command supported	0111 1101 0110 0001B 7D61H
84	Command and feature sets supported Bit 15: Shall be cleared to zero Bit 14: Shall be set to one Bit 13: If set, Idle Immediate with Unload Feature supported Bit 12: Reserved Bit 11: Reserved Bit 9-10: Obsolete Bit 8: If set, 64-bit World wide name supported Bit 7: If set, Write DMA Queued FUA EXT command supported Bit 6: If set, Write DMA FUA EXT and Write Multiple FUA EXT commands supported Bit 5: If set, General Purpose Logging feature set supported Bit 4: If set, Streaming Feature Set supported Bit 3: Obsolete Bit 2: If set, Media serial number supported Bit 1: If set, SMART Self-Test supported Bit 0: If set, SMART Error Logging supported	0100 0001 0010 0011B 4123H
85	Command and feature sets supported or enabled Bit 15: Obsolete Bit 14: If set, NOP command supported Bit 13: If set, Read Buffer command supported Bit 12: If set, Write Buffer command supported Bit 11: Obsolete Bit 10: If set, Host Protected Area has been established Bit 9: If set, DEVICE RESET command supported Bit 8: If set, SERVICE interrupt enabled Bit 7: If set, Release Interrupt enabled Bit 6: If set, Read look-ahead enabled Bit 5: If set, Volatile Write cache enabled Bit 4: Cleared to 0 to indicate that the PACKET feature set is not supported Bit 3: Set to 1 to indicate that the Mandatory Power Management feature set is supported Bit 2: Obsolete Bit 1: If set, Security Feature Set enabled Bit 0: If set, SMART Feature Set enabled	0111 0X0X XXX0 10XXB

86	<p>Commands and feature sets supported or enabled</p> <ul style="list-style-type: none"> <li>Bit 15: If set, Words 119-120 are valid</li> <li>Bit 14: Reserved</li> <li>Bit 13: If set, Flush Cache EXT command supported</li> <li>Bit 12: If set, Flush Cache command supported</li> <li>Bit 11: If set, Device Configuration Overlay supported</li> <li>Bit 10: If set, 48-bit Address Feature Set supported</li> <li>Bit 9: Not supported</li> <li>Bit 8: If set, Set Max Security Extension enabled by Set Max Set Password</li> <li>Bit 7: Reserved</li> <li>Bit 6: If set, Set Features subcommand required to spin-up after power-up</li> <li>Bit 5: If set, Power-Up In Standby feature set enabled</li> <li>Bit 4: Obsolete</li> <li>Bit 3: If set, Advanced Power Management feature set enabled</li> <li>Bit 2: If set, CFA Feature Set enabled</li> <li>Bit 1: If set, Read/Write DMA Queued command supported</li> <li>Bit 0: If set, Download Microcode command supported</li> </ul>	1011 11XX 01X0 X001B
87	<p>Commands and feature sets supported or enabled</p> <ul style="list-style-type: none"> <li>Bit 15: Shall be cleared to zero</li> <li>Bit 14: Shall be set to 1</li> <li>Bit 13: If set, Idle Immediate with Unload Feature supported</li> <li>Bit 12: Reserved</li> <li>Bit 11: Reserved</li> <li>Bit 9-10: Obsolete</li> <li>Bit 8: If set, 64-bit World wide name supported</li> <li>Bit 7: If set, Write DMA Queued FUA EXT command supported</li> <li>Bit 6: If set, Write DMA FUA EXT and Write Multiple FUA EXT commands supported</li> <li>Bit 5: If set, General Purpose Logging Feature Set supported</li> <li>Bit 4: Obsolete</li> <li>Bit 3: If set, Media Card Pass Through Command feature set supported</li> <li>Bit 2: If set, Media serial number is valid</li> <li>Bit 1: If set, SMART Self-Test supported</li> <li>Bit 0: If set, SMART Error Logging supported</li> </ul>	0100 0001 0010 XX11B
88	<p>Ultra DMA modes</p> <ul style="list-style-type: none"> <li>Bit 15: Reserved</li> <li>Bit 14: If set, Ultra DMA Mode 6 is selected</li> <li>Bit 13: If set, Ultra DMA Mode 5 is selected</li> <li>Bit 12: If set, Ultra DMA Mode 4 is selected</li> <li>Bit 11: If set, Ultra DMA Mode 3 is selected</li> <li>Bit 10: If set, Ultra DMA Mode 2 is selected</li> <li>Bit 9: If set, Ultra DMA Mode 1 is selected</li> <li>Bit 8: If set, Ultra DMA Mode 0 is selected</li> <li>Bit 7: Reserved</li> <li>Bit 6: Ultra DMA mode 6 supported</li> <li>Bit 5: Ultra DMA mode 5 supported</li> <li>Bit 4: Ultra DMA mode 4 supported</li> <li>Bit 3: Ultra DMA mode 3 supported</li> <li>Bit 2: Ultra DMA mode 2 supported</li> <li>Bit 1: Ultra DMA mode 1 supported</li> <li>Bit 0: Ultra DMA mode 0 supported</li> </ul>	XXXX XXXX 0111 1111B
89	<p>Bit 15-8: Reserved Bit 7-0: Time required for Normal Erase mode SECURITY ERASE UNIT command</p>	XXH
90	<p>Bit 15-8: Reserved Bit 7-0: Time required for Normal Erase mode SECURITY ERASE UNIT command</p>	XXH
91	Current APM level value	XXXXXH
92	Master Password Identifier	XXXXXH
93	Hardware reset result	0
94	Obsolete	0
95	Stream Minimum Request Size	0
96	Stream Transfer Time - DMA	0
97	Stream Access Latency -DMA and PIO	0

98-99	Stream Performance Granularity (Dword)	0
100-103	Total number of User Addressable Logical Sectors (QWord)	WD30PURX (5,860,533,168) WD20PURX (3,907,029,168) WD30PURZ (5,860,533,168) WD20PURZ (3,907,029,168) WD30EVX (5,860,533,168) WD20EVX (3,907,029,168)
104	Streaming Transfer Time - PIO	0
105	Maximum number of 512 byte blocks per Data Set Management command	0
106	Physical sector size / logical sector size Bit 15 Shall be cleared to zero Bit 14 Shall be set to one Bit 13 if set, Device has multiple logical sectors per physical sector. Bit 12 if set, Device Logical Sector longer than 256 Words Bits 11-4 Reserved Bits 3-0 2X logical sectors per physical sector	6003H
107	Inter-seek delay for ISO 7779 standard acoustic testing	0
108-111	World Wide Name	XXXXXXXXXXXXXXXXXX
112-115	Reserved	0
116	Reserved for TLC	0
117-118	Logical Sector size (DWord)	0
119	Commands and feature sets supported (Continued from words 82-84) Bit 15: Cleared to zero Bit 14: Shall be set to one Bit 13-8: Reserved Bit 7: If set, Extended Power Conditions feature set supported Bit 6: If set, Sense Data Reporting supported Bit 5: If set, Free-fall Control feature set is supported Bit 4: If set, DOWNLOAD MICROCODE with offsets is supported Bit 3: If set, READ and WRITE DMA EXT GPL optional commands are supported Bit 2: If set, WRITE UNCORRECTABLE EXT is supported Bit 1: If set, Write-Read-Verify feature set is supported Bit 0: Reserved for DDT	0100 0000 0001 1100B 401CH
120	Commands and feature sets supported (Continued from words 85-87) Bit 15: Cleared to zero Bit 14: Shall be set to one Bit 13-8: Reserved Bit 7: If set, Extended Power Conditions feature set supported Bit 6: If set, Sense Data Reporting supported Bit 5: If set, Free-fall Control feature set is supported Bit 4: If set, DOWNLOAD MICROCODE with offsets is supported Bit 3: If set, READ and WRITE DMA EXT GPL optional commands are supported Bit 2: If set, WRITE UNCORRECTABLE EXT is supported Bit 1: If set, Write-Read-Verify feature set is supported Bit 0: Reserved for DDT	0100 0000 0001 1100B 401CH
121-126	Reserved	0

127	Obsolete	0
128	Security Status Bit 15-9: Reserved Bit 8: Security level (0 = High, 1 = Maximum) Bit 7-6: Reserved Bit 5: If set, Enhanced Security Erase supported Bit 4: If set, Security count expired Bit 3: If set, Security Frozen Bit 2: If set, Security Locked Bit 1: If set, Security enabled Bit 0: If set, Security supported	0000 000X 001X XXX1B
129-159	Vendor Specific	0
160	CFA power mode Bit 15: Word 160 supported Bit 14: Reserved Bit 13: CFA power mode Bit 12: CFA power mode 1 disable Bit 11-0: Maximum current in ma	0
161-167	Reserved for the CompactFlash™ Association	0
168	Device Nominal Form Factor Bit 15-4: Reserved Bit 3-0: Device Nominal Form Factor	0
169	Data Set Management Command Bit 15-1: Reserved Bit 0: if set, the Trim bit in the Data Set Management command supported	0
170-173	Additional Product Identifier	0
174-175	Reserved	0
176-205	Current Media Serial number	0
206	SCT Command Transport Bit 15-12: Vendor Specific Bit 11-6: Reserved Bit 5: If set, SCT Data tables command supported Bit 4: If set, SCT Features Control command supported Bit 3: If set, SCT Error Recovery Control command supported Bit 2: If set, SCT Write Same command supported Bit 1: If set, Obsolete Bit 0: If set, SCT Command Transport supported	0111 0000 1011 0101B 70B5H
207-208	Reserved	0
209	Alignment of logical blocks within a physical block Bit 15: Shall be cleared to zero Bit 14: Shall be set to one Bits 13-0: Logical sector offset within the first physical sector where the first logical sector is placed.	0
210-211	Write-Read-Verify Sector Count Mode 3	0
212-213	Write-Read-Verify Sector Count Mode 2	0
214	NV Cache Capabilities Bit 15-12: NV Cache feature set version Bit 11-8: NV Cache Power Mode feature set version Bit 7-5: Reserved Bit 4: If set, NV Cache feature set enable Bit 3-2: Reserved Bit 1: If set, NV Cache Power Mode feature set enable Bit 0: if set, NV Cache Power Mode feature set supported	0
215-216	NV Cache Size in Logical Blocks	0
217	Nominal media rotation rate	0
218	Reserved	0
219	NV Cache Options Bit 15-8: Reserved Bit 7-0: Device Estimate Time to spin up in seconds	0

220	Bit 15-8: Reserved Bit 7-0: Write-Read-Verify feature set current mode	0
221	Reserved	0
222	Transport major version number 0000h or FFFFh=device does not report version Bit 12-15: Transport Type (0h=Parallel 1h=Serial 2h-Fh=Reserved) Bit 6-11: Reserved (Parallel, Serial) Bit 5: Reserved SATA Rev. 3.0 Bit 4: Reserved SATA Rev. 2.6 Bit 3: Reserved SATA Rev. 2.5 Bit 2: Reserved SATA II: Extensions Bit 1: ATA/ATAPI-7 SATA 1.0a Bit 0: ATA8-APT ATA8-AST	0001 0000 0011 1110B 103EH
223	Transport minor version number	0
224-229	Reserved	0
230-233	Extended Number of User Addressable Sectors (Qword)	0
234	Minimum number of 512-byte data blocks per DOWNLOAD MICROCODE command for mode 03h	0001H
235	Maximum number of 512-byte data blocks per DOWNLOAD MICROCODE command for mode 03h	1000H
236-254	Reserved	0
255	Integrity Word Bit 15-8: Checksum Bit 7-0: Signature	XXA5H



#### 4.4 Set Features (EFh)

The Set Features command enables or disables the features listed in the following table.

FUNCTION	FEATURES REGISTER	SECTOR COUNT REGISTER
Enable read look-ahead <sup>1</sup>	AAH	DON'T CARE
Disable read look-ahead <sup>1</sup>	55H	DON'T CARE
Enable write cache <sup>1</sup>	02H	DON'T CARE
Disable write cache <sup>1</sup>	82H	DON'T CARE
Set Transfer Mode	03H	DON'T CARE
Enable use of Serial ATA Feature	10H	02h-DMA Setup FIS Auto-Activate optimization 06h-Software Settings Preservation
Disable use of Serial ATA Feature	90H	02h-DMA Setup FIS Auto-Activate optimization 06h-Software Settings Preservation

**Note:** Changes are only valid while power remains applied to the drive. After power is cycled, the drive reverts to the default settings.

## 5.0 INSTALLATION AND SETUP PROCEDURES

Hard drives are precision instruments that must be handled with care to prevent damage. It is important to understand that drives are typically damaged because of Electrostatic Discharge (ESD), rough handling, or shock and vibration. Refer to the WD 3.5-inch Hard Drive Handling poster (part number 2378-701046) for details on drive handling.

Refer to <http://support.wd.com/warranty> for detailed instructions on all phases of repackaging the drive.

**Important:** If your system does not support hot plugging (see "Hot Plug Support" on page 20), it must be turned off and unplugged before installing your hard drive.

### 5.1 Unpacking

#### 5.1.1 Handling Precautions

WD products are designed to withstand normal handling during unpacking and installation. Take care to avoid excessive mechanical shock or electrostatic discharge (ESD), which can permanently damage the hard drive and void the warranty. Hard drives are typically damaged because of ESD, rough handling, or shock and vibration.

To avoid ESD problems, wear a properly grounded wrist strap when handling the hard drive. Articles of clothing generate static electricity. Do not allow clothing to come in direct contact with the hard drive or circuit board components.

When the WD drive is not in its shipping container or installed in its proper host enclosure, it must remain in the antistatic bag. To prevent damage, do not unpack your WD drive until you are ready to install it.

#### 5.1.2 Inspection of Shipping Container

Carefully examine the container for obvious shipping damage, such as: holes, signs of crushing, or stains. Notify the carrier and your WD representative if you observe any shipment damage. Always move the shipping container in the upright position indicated by the arrows on the container.

#### 5.1.3 Removal From Shipping Container

Remove the WD drive from the shipping container only for inspection or installation. Carefully open the box. When removing the WD drive from the box, follow these precautions:

- Grasp the drive by the sides only; avoid touching the circuit board components.
- Gently place the drive on its antistatic bag on a clean, level, grounded work area.
- Do not stack drives or stand the WD drive on its edge.

**CAUTION:** When removing the drive from the shipping container, be careful not to drop it. Dropping the drive can severely damage the head disk assembly or printed circuit board.

### 5.1.4 Removal From Static Shielding Bag

Before removing the drive from its static shielding bag:

- Make sure that your work station is properly grounded.
- Wear a properly grounded wrist strap with good skin contact.
- Avoid contact with any component on the printed circuit board.

After attaching your wrist strap, gently remove the drive from the static shielding bag.

- Handle the drive by the sides only; avoid touching the printed circuit board.
- Handle the drive with the printed circuit board facing downward during installation.
- Do not open the drive's sealed compartment or remove the seals or any labels from the drive; this will void the warranty.

### 5.1.5 Moving Precautions

If you need to move your computer, turn off the power to automatically unload the heads. This helps protect the media and the heads from accidental damage due to vibration, moving, or shipping.

## 5.2 Mounting

Use either the four bottom screws or at least four of the side mounting screws to rigidly support the drive and prevent vibration. Some adaptor frames may not have the mechanical design structure capable of mounting the drive to meet the specified shock and vibration requirements.

The hard drive itself does not provide electrical isolation between mounting locations and drive ground connection. If electrical isolation is required, the system designer or integrator would be responsible for providing a solution.

### 5.2.1 Mounting Restrictions

If your system does not support hot plugging (see "Hot Plug Support" on page 20), it must be turned off and unplugged before installing your hard drive.

### 5.2.2 Orientation

You can mount the hard drive in the X, Y, or Z axis, depending upon the physical design of your system. For best results, mount the drive with all four screws grounded to the chassis. If all four screws are not used, see "Grounding" on page 42.

### 5.2.3 Screw Size Limitations

The hard drive should be mounted to the chassis using four 6-32 screws. Recommended screw torque is 5 in-lb. Maximum screw torque is 10 in-lb.

**CAUTION: Screws that are too long can damage the hard drive. Hard drive screw penetration can differ between products depending upon hard drive design. WD's minimum design criteria is to always meet the SFF 8301 industry standard specification. The industry standard as defined in the SFF 8301 specifies a maximum of 3 mm screw penetration, and for a minimum of 2.4 mm of thread engagement from both the screw and the hard drive.**

**See Figure 2-1 for allowable fastener penetration for this product family.**

### 5.2.4 Grounding

The PCBA and HDA grounds are always connected together in the drive and cannot be disconnected. The drive mounting screws, unless intentionally isolated, will provide additional ground connections between the HDA and the system chassis. If the drive isn't grounded via mounting screws as described under "Mounting" on page 41, there may be increased electrical emissions (EMI).

## 5.3 Hard Drive Installation

If your system does not support hot plugging (see "Hot Plug Support" on page 20), it must be turned off and unplugged before installing your hard drive.

### 5.3.1 Jumper Settings

It is not necessary to place a jumper shunt on the drive for workstation/desktop use. For enterprise storage environments, the advanced settings are as follows:

**SSC Mode** – Spread spectrum clocking feature enabled or disabled (jumper on pins 1-2). Default setting is disabled.

**PUIS Enabled Mode** – To designate the drive as power-up in standby (power management 2 or PM2) enabled, place a jumper on pins 3-4 (default setting is disabled). This mode enables controlled spinup via spinup command per ATA standard. It is mainly used for server/workstation environments operating in multiple drive configurations.

**Important:** PUIS mode requires a compatible BIOS that supports this feature. If PUIS is enabled and not supported by BIOS, the drive will not spin up and therefore will not be detected by the system.

**Native Gen2 Enabled Mode** – To revert to the SATA 3 Gb/s data transfer speed, place a jumper on pins 5-6.

**Force Gen1 Enabled Mode** – To revert to the SATA 1.5 Gb/s data transfer speed, place jumpers on pins 5-6 and 7-8.

Figure 5-1. Jumper Settings

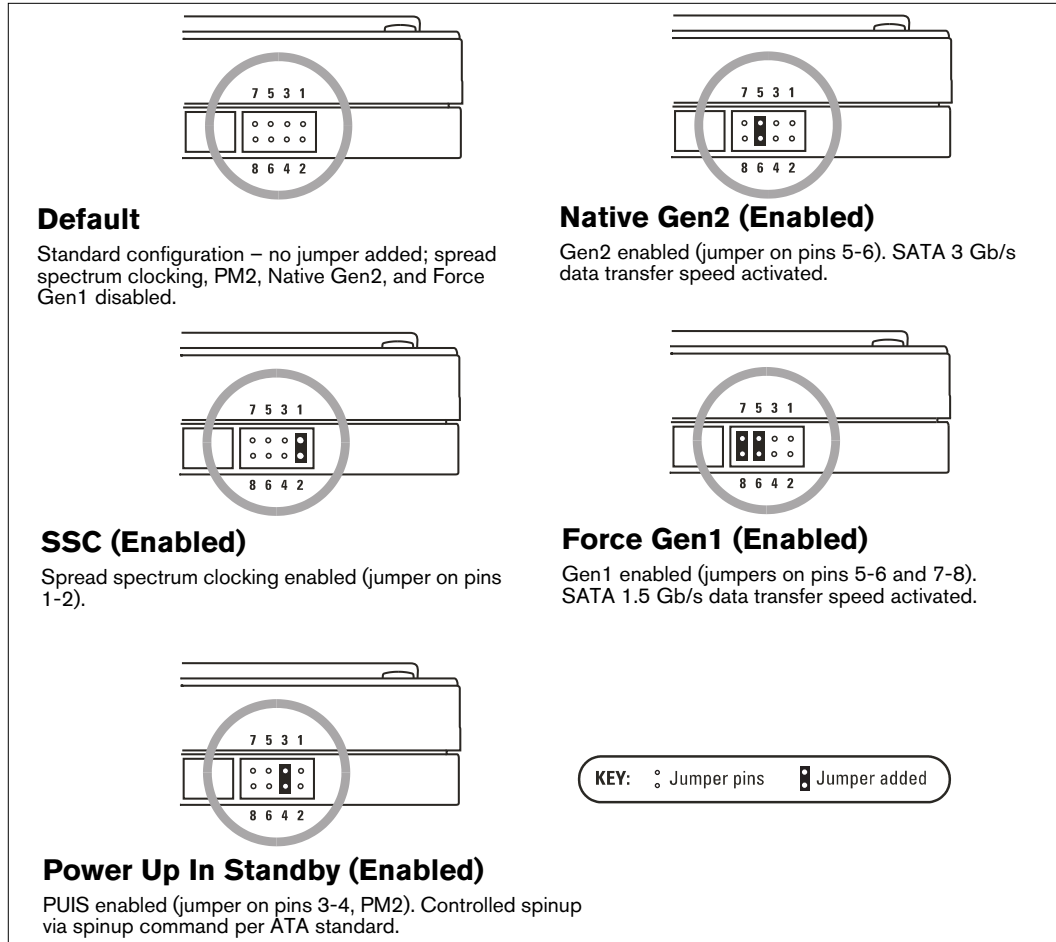

### 5.3.2 ATTACH THE POWER SUPPLY CABLE

If your system does not support hot plugging (see "Hot Plug Support" on page 20), it must be turned off and unplugged before installing your hard drive. This avoids the possibility of reversing the polarity of the power connections and eliminating current surges that can damage either the drive or computer.

Attach the SATA power supply cable to the SATA device plug power connector (see "Standard Factory Connectors" on page 10). The SATA power connector is keyed to ensure proper insertion.

Figure 5-2. Connector Locations

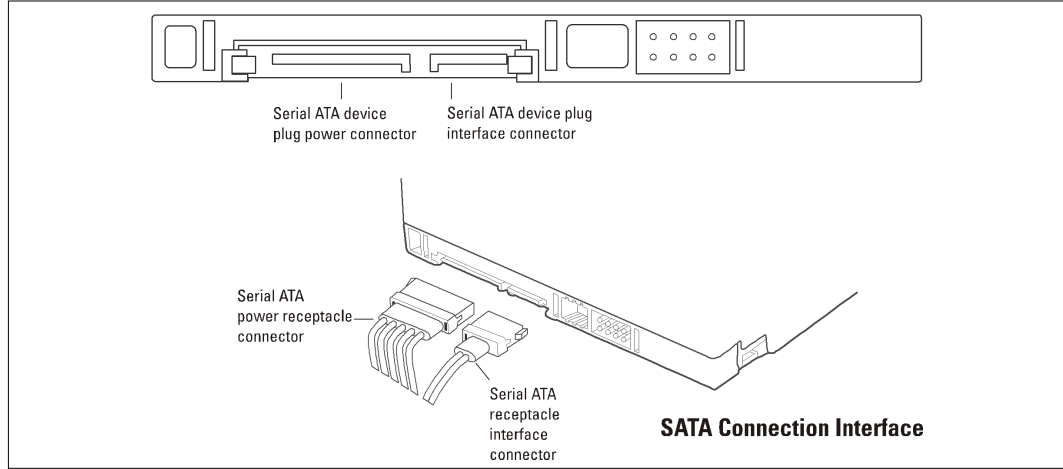

### 5.3.3 ATTACH SATA INTERFACE CABLE

You can configure the hard drive two ways:

1. Cable the drive directly to a SATA connector on the motherboard, or
2. Cable the drive to a host adapter card mounted in one of the expansion slots in the computer.

Both configurations use a SATA interface cable.

Make sure the SATA interface cable is no longer than 1 meter (39.37 inches) to minimize noise that is induced on the data and control buses.

Figure 5-3. SATA Interface Cable

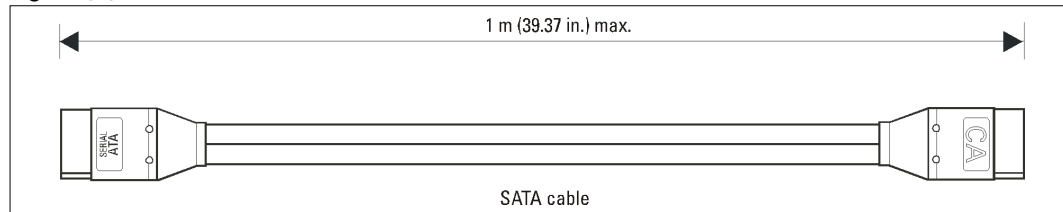

### 5.4 Serial ATA Latching Connector

This hard drive also allows Serial ATA latching cable connections. The latching connector provides a secure connection between the drive and the cable connector via a locking latch mechanism. The new latching connector design has two channels, one above the power connection and one above the data connection. Latch alignment with these channels forms an interlock when the latching cable is inserted into the drive. This latching feature makes the SATA connector more robust against

breakage from downward force and ensures a click-lock connection which is verifiable even in noisy environments.

## 6.0 MAINTENANCE

The hard drive requires no preventative maintenance and contains no user-serviceable parts. The service and repair of drives can only be performed at a WD Service Center. Please contact your WD representative for warranty information and service/return procedures.

Observe the following precautions to prolong the life of the drive:

- Do not attempt to open the sealed compartment of the drive as this will void the warranty.
- Do not lift a drive by the printed circuit board.
- Avoid static discharge when handling a drive.
- Avoid harsh shocks or vibrations.
- Do not touch the components on the printed circuit board.
- Observe the environmental limits specified for this product.
- If it becomes necessary to move your computer system, turn off the power to automatically unload the heads. This helps protect the media and the heads from accidental damage due to vibration while moving or shipping.
- To protect your data, back it up regularly. WD assumes no responsibility for loss of data. For information about back-up and restore procedures, consult your operating system manual. There are also a number of utility programs available that you can use to back up your data.



## 7.0 TECHNICAL SUPPORT

### NORTH AMERICA

**US/Canada** (Central Time) **800.ASK.4WDC (800.275.4932)**

*Monday - Thursday* 8:00 am - 9:00 pm

*Friday - Sunday* 8:00 am - 7:00 pm

### EUROPE

**Central European Time (CET)** **00800.27549338 (toll-free where available) or +31.880062100**

*Monday - Thursday* 9:00 am - 7:00 pm

*Friday* 9:00 am - 5:00 pm

## 7.1 WD Online Services

WD provides a wide variety of technical support services on our Internet site at <http://support.wd.com>.

## 8.0 GLOSSARY

**Active LED Status** — The WD drive supports external LED requirements. It provides an activity LED output which is ON during command execution and OFF otherwise.

**Annualized Failure Rate (AFR)** — A method of measuring failure rates or trends for a group of units at a site. The rates are based on the monthly total number of returned field failure units divided by the total cumulative installed base and multiplied by 12 (to annualize the failure rate).

**Advanced Format (AF)** — Technology adopted by WD and other drive manufacturers as one of multiple ways to continue growing hard drive capacities. AF is a more efficient media format that enables increased areal densities.

**AllFrame 4K™** — AllFrame 4K™ technology improves ATA streaming to help reduce frame loss, improve overall video playback, and increase the number of hard drive bays supported within a NVR.

**Automatic Defect Retirement** — If defective sectors are found during a read or write, they are automatically mapped out and relocated.

**Block** — A group of bytes handled, stored, and accessed as a logical data unit, such as an individual file record.

**Buffer** — A temporary data storage area that compensates for a difference in data transfer rates and/or data processing rates between sender and receiver.

**Command Queuing** — See *Native Command Queuing (NCQ)*

**Data Lifeguard™** — Representing WD's ongoing commitment to data protection, Data Lifeguard data protection utilities include thermal management, an environmental protection system, and embedded error detection and repair features that automatically detect, isolate, and repair problem areas that may develop over the extended use of the hard drive.

**Data Transfer Rate** — The rate that digital data is transferred from one point to another, expressed in bits per second or bytes per second.

**Defect Management** — A general methodology of eliminating data errors on a recording surface by mapping out known bad areas of the media.

**Dual Stage Actuator Technology** — A head positioning system with dual-stage actuators that improves positioning accuracy over the data track(s). The primary stage provides course displacement; the secondary stage uses piezo electric motion to fine tune the head positioning to a higher degree of precision.

**Dynamic Fly Height Control** — This feature is designed to compensate for head/media separation changes due to temperature and altitude. It adds video quality margins across temperature and altitude changes.

**Error Correction Code (ECC)** — A mathematical algorithm that can detect and correct errors in a data field by adding check bits to the original data.

**Femto Slider** — These drives incorporate the femto slider form factor in which the read/write head is mounted on the small, lightweight femto slider which allows the head to move more quickly from track to track on the disk.

**F.I.T. (Functional Integrity Testing)** — A suite of tests WD performs on all its drive products to ensure compatibility with different hosts, operating systems, application programs, and peripherals. This testing must be performed before the product can be released to manufacturing.

**Fluid Dynamic Bearings (FDB)** — Bearing design that incorporates a layer of high-viscosity lubricant instead of ball bearings in the hard drive spindle motor. FDB designs provide increased non-operational shock resistance, speed control, and improved acoustics.

**Formatted Capacity** — The actual capacity available to store data in a mass storage device. The formatted capacity is the gross capacity minus the capacity taken up by the overhead

data required for formatting the media.

**Hot Plugging** — The ability to swap out a failed hard drive without having to power down the system or reboot.

**Latency** — The period of time that the read/write heads wait for the disk to rotate the data to an accessible position. For a disk rotating at 10,000 RPM, the average latency is 3 milliseconds.

**IntelliPower** — A fine-tuned balance of spin speed, transfer rate and caching algorithms designed to deliver both significant power savings and solid performance. Additionally, these drives consume less current during startup allowing lower peak loads on systems as they are booted.

**IntelliSeek** — WD technology that proactively calculates an optimum seek speed to eliminate hasty movement of the actuator that produces noise and requires power.

**Logical Block Address** — An alternative addressing methodology of identifying a given location on a SATA drive that permits disk sizes greater than 528 MB.

**Native Command Queuing (NCQ)** — NCQ allows the drive to re-order read commands, thereby increasing random read IOPs. NCQ is a true Enterprise feature for environments such as database, Web servers, and e-mail servers.

**NoTouch™ Ramp Load Technology** — The recording head never touches the disk media ensuring significantly less wear to the recording head and media as well as better drive protection in transit.

**Pre-emptive Wear Leveling (PWL)** — WD feature that provides a solution for protecting the recording media against mechanical wear.

**PRML (Partial Response Maximum Likelihood)** — A read channel using sampled data, active equalization and Viterbi detection to accurately retrieve the user data off the disk.

**RoHS (Restriction of Hazardous Substances)** — WD hard drive products manufactured and sold worldwide after June 1, 2006, meet or exceed Restriction of Hazardous Substances (RoHS) compliance requirements as mandated by the RoHS Directive 2011/65/EU.

**Rotational Latency** — The amount of delay in obtaining information from a disk drive that can be attributed to the rotation of the disk. For a disk rotating at 10,000 RPM, the average latency is 3 milliseconds.

**RPM (Revolutions per Minute)** — Rotational speed of the media (disk), also known as the spindle speed. Hard drives spin at one constant speed. The slower the RPM, the higher the mechanical latencies. Disk RPM is a critical component of hard drive performance because it directly impacts the rotational latency of the disk transfer rate.

**Seek Time** — The time it takes for the read/write head to move to a specific block of data on the hard drive. The average seek time is computed by dividing the time it takes to complete a large number of random seeks by the number of seeks performed.

**Sector** — A 512-byte packet of data.

**Self-Monitoring, Analysis, and Reporting Technology (S.M.A.R.T.)** — A technology to assist the user in preventing possible system down time due to hard drive failure.

**Serial ATA (SATA)** — SATA is the industry standard bus interface for hard drives. It is designed to replace Parallel ATA, and has many advantages including increased transfer rate, improved signal integrity, enhanced data protection, and hot plugging.

**S.M.A.R.T. Command Transport (SCT)** — The SCT Command Transport feature set provides a method for a host to send commands and data to a device and for a device to send data and status to a host using log pages.

**Staggered Spinup** — SATA feature that allows the system to control whether the drive will spin up immediately or wait until the interface is fully ready.

**Unrecoverable Error** — A read error that cannot be overcome by an ECC scheme or by rereading the data when host retries are enabled.

**World Wide Name (WWN)** — The World Wide Name (WWN) defined in ATA/ATAPI-7 is a modification of the IEEE extended unique identifier 64 bit standard (EUI-64) and is comprised of three major components: naming authority, organizationally unique identifier (OUI) and serial number. WD's OUI is 0014EEh.

**Write Cache** — A feature in CacheFlow that posts "command complete" prior to completing the actual write.

**INDEX****—A—**

Acoustics, 9, 12  
 Active LED Status, 20  
 Activity indication, 21  
 Advanced Format, 15  
 AF, 15  
 Agency Approvals, 12  
 Airflow, 9  
 AllFrame, 14  
 Annualized Failure Rate, 48  
 Atmospheric Pressure, 9  
 Automatic Defect Retirement, 19

**—B—**

Buffer Size, 4  
 bytes per sector  
   host, 4  
   physical, 4

**—C—**

Cabling, 6  
   Power Supply Cable Attachment, 44  
   SATA Interface Cable Attachment, 44  
   SATA Interface Cable Diagram, 44  
 CacheFlow6, 21  
 Commands  
   SCT, 27  
 Connectors  
   Serial ATA Latching, 44  
 Cooling  
   Airflow, 9  
   forced airflow direction, 9  
 Current Requirements, 6

**—D—**

Data Lifeguard, 17  
 Data Surfaces, 4  
 Data Transfer Rate, 4  
 Defect Management, 19  
 Device Plug Connector Pin Definitions, 10, 11  
 Dimensions, 5  
 Dynamic fly height control, 15

**—E—**

Error Rate, 4  
 Error Recovery Process, 19

**—F—**

Femto slider, 16  
 Fluid Dynamic Bearings (FDB), 21

**—G—**

Glossary, 48  
 Grounding (Hard Drive), 42

**—H—**

Host Interface Commands, 25  
   Identify Drive, 31  
   S.M.A.R.T., 27  
   Set Features, 39  
 Hot Plug Support, 20

**—I—**

Input Voltage Requirements, 6  
 Installation and Setup, 40  
 IntelliPower, 14  
 Internal Environmental Protection System, 18

**—J—**

Jumper Settings, 42

**—L—**

LED  
   active status, 20  
   activity indication, 21  
 Logical Block Addressing  
   48-bit, 22

**—M—**

Maintenance, 46  
 Model number specification, 12  
 Mounting  
   Orientation, 41  
   Screw Size Limitations, 41  
 Mounting (Hard Drive), 41

**—N—**

Native Command Queuing, 16  
 NoTouch, 15

**—P—**

Perpendicular magnetic recording (PMR), 15  
 Power, 6  
 Power Dissipation, 6, 8  
 Power management, 22  
 Pre-emptive Wear Leveling (PWL), 16  
 PWL, 16

**—R—**

Ramp load (NoTouch), 15  
 Read Cache, 22  
 Recording Method, 4  
 Reliability features set, 17  
 Ripple, 6  
 RoHS (Restriction of Hazardous Substances), 9  
 Rotational Speed, 4

RPM, 4

### —S—

S.M.A.R.T., 24

S.M.A.R.T. Command Transport (SCT), 16

SATA 6 Gb/s interface, 14

SCT, 16

SCT commands, 27

SCT feature set

    temperature reporting, 17

    write same, 16

Security Mode, 24

    Passwords, 24

    Security Levels, 24

Serial ATA Latching Connector, 44

Servo Type, 4

Shock and Vibration, 7

Specifications, 4

    electrical (3 disk models), 6

    Environmental, 7

    Mechanical, 5

    Performance, 4

    Physical, 4

    Reliability, 10

Spindle Start Time, 4

Staggered Spinup, 21

### —T—

Technical Support, 47

    Online Services, 47

Temperature

    Airflow, 9

    Thermocouple location, 8

Temperature and Humidity, 8

Thermal Management, 18

Thermocouple location, 8

### —U—

Unpacking

    Container Inspection, 40

    Drive Removal - Container, 40

    Drive Removal - Static Shielding Bag, 41

    Handling Precautions, 40

    Moving Precautions, 41

User Sectors per Drive, 4

### —W—

World Wide Name (WWN), 17

Write Cache, 22

WWN, 17

Western Digital  
3355 Michelson Drive, Suite 100  
Irvine, California 92612 U.S.A.

**For service and literature:**

<http://support.wd.com>  
[www.wd.com](http://www.wd.com)

800.ASK.4WDC North America  
949.832.4778 Latin America (Spanish)  
+800.6008.6008 Asia Pacific  
00800.ASK.4WDEU Europe (toll free where available)  
+31.88.0062100 Europe/Middle East/Africa

2679-800020-A03-P3  
May 2017



WD CONFIDENTIAL